

ABB industrial drives

ACS800, single drives, 0.55 to 2800 kW

Technical catalogue



Contents



Type code

ACS800

-

01
11
31
02
07
17
37

-

XXXX

-

X

+

XXXX

1

Product series

2

Single drives
Types and constructions
Ratings
Voltages

Dimensions

3

Hardware options

4

Control connections and communications

5

Application software and programming

6

PC tools

7

Summary of features and options

8

Services

9

Contact and web information



ABB industrial drives, single drives

ABB industrial drives.....	4	1
Single drive main features	8	
Technical specification	10	
Wall-mounted drives, ACS800-01	11	2
Wall-mounted regenerative drives, ACS800-11	14	
Wall-mounted low harmonic drives, ACS800-31	16	
Free-standing drives, ACS800-02	18	
Cabinet-built drives, ACS800-07	20	
Cabinet-built regenerative drives, ACS800-17	24	
Cabinet-built low harmonic drives, ACS800-37.....	27	
Brake options	30	3
EMC filters.....	33	
Sine filters.....	34	
Sine filter drives	36	
du/dt filters	37	
Standard user interface		4
Control panel	39	
Standard I/O	40	
Options		
Optional I/O	41	
Fieldbus control	42	
Remote monitoring and diagnostics tool	43	
Standard application software	44	5
Optional application software		
Control solutions for different applications	45	
DriveSize	47	6
DriveAP	48	
DriveWindow 2	49	
DriveWindow Light 2	50	
DriveOPC	51	
Table	52	7
Services	54	8
www.abb.com/motors&drives	55	9



ABB industrial drives

ACS800 - 01 - XXXX - X + XXXX

11
31
02
07
17
37

ABB industrial drives

ABB industrial drives are designed for industrial applications, and especially for applications in process industries such as the pulp & paper, metals, mining, cement, power, chemical, and oil & gas. ABB industrial drives are available both as complete AC drives and as modules to meet the requirements of the users, OEMs and system integrators. These drives are highly flexible AC drives that can be configured to meet the precise needs of industrial applications, and hence order-based configuration is an integral part of the offering. The complete drives and drive modules cover a wide range of powers and voltages, including industrial voltages up to 690 V. ABB industrial drives come with a wide range of inbuilt options. A key feature of these drives is programmability, which makes adaptation to different applications easy.

Industrial design

ABB industrial drives are designed with current ratings to be used in industrial environment for applications requiring high overloadability. The heart of the drive is DTC, Direct Torque Control, that provides high performance and significant benefits: e.g. accurate static and dynamic speed and torque control, high starting torque and long motor cables. Inbuilt drive options make the installation work fast and easy. The robust enclosures and cabinets, with a wide range of enclosure classes, as well as power terminals, are designed for harsh environments.

One of the most significant design criteria of ABB industrial drives has been the long lifetime. Wearing parts such as fans and capacitors have been selected accordingly. This means - together with extensive protection features - excellent reliability in the demanding industrial market.



Industrial^{IT} enabled

ABB industrial drives are Industrial^{IT} enabled. This guarantees the user that ABB industrial drives can be easily integrated into ABB Industrial IT systems.

Single drives

The single drive configuration contains a rectifier, DC link and an inverter in one single AC drive unit.

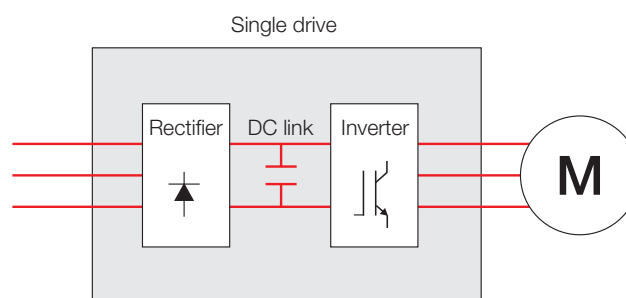

The single drives are complete AC drives that can be installed without any additional cabinet or enclosure. The single drives are available as wall-mounted, free-standing and cabinet-built constructions. The protection degree of the single drives is at least IP21, and higher protection degrees are available as an option.

Type code

This is the unique reference number that clearly identifies your drive by construction, power rating voltage and selected options. By type code you can specify your drives from the wide range of available options, customer specific ones are added to the type code using the corresponding + code.

Other products

Please also see the separate technical catalogues ACS800, multidrive, code 3AFE68248531 EN and ACS800, drive modules, code 3AFE68404592 EN.



ABB industrial drives



Wall-mounted drives, ACS800-01

The wall-mounted drive, ACS800-01 offers all that you need up to 110 kW. All important features and options are built inside the drive: line choke, EMC filter, brake chopper etc. The user gets everything in a single and complete IP21 or IP55 package. Still the drive is also extremely small. A wide range of software alternatives makes this drive suitable for any application.

Wall-mounted drives, ACS800-01 for marine applications

The type approved ACS800-01 marine drive provides advanced reliability and availability at sea. The drive fulfils marine and offshore requirements, and the design and operation have been tested according to marine type approval requirements. The ACS800-01 has marine type certification from ABS, BV, DNV, GL, Lloyd's, and RINA.

Wall-mounted regenerative drives, ACS800-11

The wall-mounted regenerative drive, ACS800-11 is equipped with active supply unit. It offers a full performance regenerative drive in a single compact package. All important features and options including an LCL line filter and EMC filter are built inside the drive. The power ratings start from 5.5 kW and go up to 110 kW. It is available with IP21 protection degree.

Wall-mounted low harmonic drives, ACS800-31

The wall-mounted low harmonic drive, ACS800-31 offers a unique harmonics solution that is incorporated into the drive. It has exceptionally low line harmonic content and it fulfils even the strictest harmonic requirements without external filtering devices or multi-pulse transformer arrangements.

The wall-mounted ACS800-31 offers a low harmonic drive in one complete package up to 110 kW. Similar to other wall-mounted drives, it has all the important features and options built inside the drive. It is available with IP21 protection degree.





ABB industrial drives



Free-standing drives, ACS800-02

The free-standing drive, ACS800-02 is a new innovative bookshelf enclosure. The power ratings start from 45 kW and go up to 560 kW. The ACS800-02 is available in an extremely compact IP21 enclosure and uniquely offers two mounting directions. It also offers a wide range of inbuilt options including EMC filters, brake choppers, line apparatus such as fuse switch and contactor.



Cabinet-built drives, ACS800-07

The cabinet-built drive, ACS800-07 offers standardized configurations that can be adapted to any application. It covers a wide power range up to 2800 kW and is very compact, the largest drive is only 3.2 meters wide. It is available with IP21, IP22, IP42, IP54 and IP54R protection degrees. A wide range of inbuilt options is available and application engineering services can be offered when customization is needed.





ABB industrial drives



Cabinet-built regenerative drives, ACS800-17

The cabinet-built drive, ACS800-17 is equipped with active supply unit. It is intended to drive applications where regenerative operation is required. It covers a wide power range and has an extensive range of standardized configurations that can be adapted to any application. It is available with IP21, IP22, IP42, IP54 and IP54R protection degrees.



Cabinet-built low harmonic drives, ACS800-37

The ACS800-37 cabinet-built drive is a low harmonic solution in the power range of 45 kW up to 2800 kW. It offers a unique harmonics solution that is incorporated into the drive. Like other cabinet-built single drives, it has a wide range of standardized configurations and is available with IP21, IP22, IP42, IP54 and IP54R protection degrees.



Single drive main features



Features	Benefits	Notes
Compact and complete		
Compact size, everything integrated	Less space and installation work required.	No need to install extra components such as input chokes or EMC filter.
Inbuilt harmonic filter in all ACS800 drives	Low harmonics, meaning less interference and less heating in cables and transformers. Filter also protects the drive from line side transients.	For the lowest harmonic level, ACS800-31/-37 offer almost a harmonic free solution.
Wide range of options available	Standard solutions available from ABB that meets most of the customer needs.	Custom made solutions are available in the ACS800-07/-17/-37.
Versatile braking options	Always the optimal braking option available. No need for external braking chopper thus reducing size and installation cost.	Brake chopper inbuilt in all frame sizes (standard/optional). Regenerative braking with ACS800-11/-17.
User interface		
User friendly customer interface	Easy and fast commissioning and operation.	Clear, alphanumeric display with start-up assistant that guides through the start-up procedure. Easy to use PC tools available for commissioning, maintenance, monitoring and programming.
Versatile connections and communications	Standard I/O covers most requirements. Connectable to commonly used fieldbuses.	Extensive standard and optional I/O. I/O fulfills PELV (EN 50178).
Extensive programmability	Flexibility. Possible to replace relays or even PLC in some applications.	Two levels of programmability: 1. Parameter programming (standard) 2. Adaptive programming (free block programming) - standard feature - more blocks available as options - all I/Os are programmable
Industrial design		
Wide power and voltage range	One product series suits everywhere, meaning less training and spare parts and standardized interface to drives.	
Wide range of robust enclosures available	Suitable solutions available for different environments.	IP21 - IP55.
Robust main circuit design	Suitable for heavy industrial use. Reliable. Long motor cables can be used without extra output filters.	Components dimensioned for heavy duty and long lifetime. Advanced thermal model allows high overloadability.

Single drive main features



Features	Benefits	Notes
Industrial design		
Extensive protections	Enhanced reliability, fewer process interruptions. Possibility also to protect motors and process.	Several adjustable limits to protect other equipment also.
Galvanic isolation of I/O	Safe and reliable operation without separate isolators and relays.	Isolated input signals and relay outputs as standard.
All terminals designed for industrial use	Sufficient size even for large aluminum cables. No need for special tools in I/O cabling.	
Worldwide approvals: CE, UL, cUL, CSA, C-Tick, GOST R	Safe products that can be used everywhere in the world.	
Right performance for every application		
DTC, accurate dynamic and static speed and torque control	Excellent process control even without pulse encoder - improved product quality, productivity, reliability and lower investment cost.	
DTC - allows high overloadability and gives high starting torque	Reliable, smooth start without overdimensioning the drive.	
DTC, fast control	No unnecessary trips and process interruptions.	Fast reaction to load or voltage variations prevents tripping. Rides through power interruptions by using kinetic energy of the load.
DTC, flux optimization and sophisticated motor model	Excellent motor and drive efficiency - cost savings.	Optimal flux in the motor reduces losses.
DTC, mechanics friendly	Less stress for mechanics improves reliability.	No shock torques. No torque ripple - minimized risk for torsional vibration. Active oscillation damping.
DTC, line supply control	High performance and robust control in active supply unit.	Applies for ACS800-11/-17.
Made in ABB		
Global market leader in AC drives. Long experience.	Well proven, safe and reliable solutions. Application know-how.	
World wide service and support network	Professional support available around the world.	

Technical specification



ACS800	-	01 11 31 02 07 17 37	-	XXXX	-	X	+	XXXX
--------	---	--	---	------	---	---	---	------

Mains connection	
Voltage and power range	3-phase, $U_{2IN} = 208$ to 240 V, $\pm 10\%$, except -07, -17, -37 3-phase, $U_{3IN} = 380$ to 415 V, $\pm 10\%$ 3-phase, $U_{5IN} = 380$ to 500 V, $\pm 10\%$ 3-phase, $U_{7IN} = 525$ to 690 V, $\pm 10\%$ (600 V UL, CSA)
Frequency	48 to 63 Hz
Power factor	$\cos\phi_1 = 0.98$ (fundamental) $\cos\phi = 0.93...0.95$ (total)
Power factor (ACS800-11/-31/-17/-37)	$\cos\phi_1 = 1$ (fundamental) $\cos\phi = 0.99$ (total)
Efficiency (at nominal power)	
ACS800-0x	98%
ACS800-1x/-3x	97%

Mains connection	
Voltage for > 500 V units	3-phase output voltage $0...U_{2IN}/U_{3IN}/U_{5IN}/U_{7IN}$ please see "Filter selection table for ACS800" under the du/dt filters on page 37
Frequency	$0... \pm 300$ Hz ($0... \pm 100$ Hz for -07/-17/-37 with du/dt filters)
Field weakening point	8...300 Hz
Motor control	ABB's Direct Torque Control (DTC)
Torque control:	Torque step rise time:
Open loop	<5 ms with nominal torque
Closed loop	<5 ms with nominal torque
	Non-linearity:
Open loop	$\pm 4\%$ with nominal torque
Closed loop	$\pm 1\%$ with nominal torque
Speed control:	Static accuracy:
Open loop	10% of motor slip
Closed loop	0.01% of nominal speed
	Dynamic accuracy:
Open loop	0.3...0.4% sec. with 100% torque step
Closed loop	0.1...0.2% sec. with 100% torque step

Product compliance
CE
Low Voltage Directive 73/23/EEC with amendment 93/68/EEC
Machinery Directive 98/37/EC
EMC Directive 89/336/EEC with amendment 93/68/EEC
Quality assurance system ISO 9001 and
Environmental system ISO 14001
UL, cUL 508A or 508C and CSA C22.2 NO.14-95, C-Tick, GOST R

Environmental limits	
Ambient temperature	
Transport	-40...+70°C
Storage	-40...+70°C
Operation	-15...+50°C, no frost allowed 40...50°C at reduced output current (1% / 1°C)
Cooling method:	Dry clean air
Altitude	
0...1000 m	without derating
1000...4000 m	with derating ~ (1% / 100 m) (690 V units 1000...2000 m with derating)
Relative humidity	5 to 95%, no condensation allowed
Degree of protection	
IP21	standard for -01, -11, -31, -02, -07, -17, -37
IP22	option for -07, -17, -37
IP42	option for -07, -17, -37
IP54	option for -07, -17, -37
IP54R	option for -07, -17, -37
IP55	option for -01
R = outlet air duct connection	
Paint colour	-07, -17, -37: RAL 7035 -01, -11, -31, -02: NCS 1502-Y (RAL 90021, PMS 420 C)
Contamination levels	No conductive dust allowed
Storage	IEC60721-3-1, Class 1C2 (chemical gases), Class 1S2 (solid particles)
Transportation	IEC60721-3-2, Class 2C2 (chemical gases), Class 2S2 (solid particles)
Operation	IEC60721-3-3, Class 3C1/3C2* (chemical gases), Class 3S2 (solid particles)
Vibration marine classification	3 to 13.2 Hz: ± 1 mm amplitude (peak) 13.2 to 100 Hz: 0.7 g acceleration
C = chemically active substances	
S = mechanically active substances	
* coated circuit boards	

EMC according to EN 61800-3/A11 (2000), EN 61800-3 (2004)
2 nd environment, unrestricted distribution, category C3 - standard in -07 (frame size nxR8i), -17 and -37 (frame sizes R7i-nxR8i), option in the others
1 st environment, restricted distribution (category C2) as options up to 1000 A input current

Available options are shown in the Summary of features and options table. Please see pages 52-53.



Wall-mounted drives

ACS800-01, up to 110 kW

Compact and complete drive

The ACS800-01 offers all that you need in a single, extremely small, wall-mounted package making it a compact and complete drive. The standard degree of protection is IP21. Optional IP55 allows full performance without derating. Power ratings start from 0.55 kW heavy-duty rating and go up to 110 kW continuous load rating. There are five different mechanical frame sizes covering the power range. Each frame size is optimized in performance, size and weight.

Everything inside

From the smallest to the biggest ACS800-01 there is an extensive range of inbuilt features and options. Standard features include a choke for harmonic filtering and drive protection, extensive and flexible I/O, user-friendly control panel with Start-up Assistant feature and a silent, long lifetime cooling fan. Brake chopper is included as standard in the two smallest frame sizes R2 and R3 as well as in the 690 V R4 frame. In other frames the chopper is an inbuilt option. Inbuilt options include EMC filters and extension modules for additional I/O, fieldbus and pulse encoder.

Main standard hardware features

- Wall mounting
- IP21 protection degree
- Compact design
- Harmonic filtering choke inside
- Input rectifier protection
- Brake chopper (in frame sizes R2-R3; R4 only 690 V)
- Long lifetime cooling fan and capacitors
- Extensive, programmable I/O with galvanically isolated inputs
- Three I/O and fieldbus extension slots inside
- Alphanumeric, multilingual control panel with start-up assistant feature
- Large power terminals allowing use of a wide range of cable sizes

Options for ACS800-01

Inbuilt options:

- IP55 protection degree
- Brake chopper (in frame sizes R4-R6)
- EMC filter for 1st environment, restricted distribution according to EN 61800-3 (category C2)
- EMC filter for 2nd environment, unrestricted distribution according to EN 61800-3 (category C3)
- Analog and digital I/O extension modules
- Fieldbus modules
- Pulse encoder interface module

External options:

- Brake resistor
- Output filters
- Ethernet module

Marine type approved design.





Ratings and dimensions

ACS800-01

ACS800 - 01 - XXXX - 2 + XXXX
3

Nominal ratings		No-overload use	Light-overload use		Heavy-duty use		Noise level dBA	Heat dissipation W	Air flow m ³ /h	Type code	Frame size
I _{cont. max} A	I _{max} A	P _{cont. max} kW	I _N A	P _N kW	I _{hd} A	P _{hd} kW					
U_N = 230 V (Range 208-240 V). The power ratings are valid at nominal voltage 230 V.											
5.1	6.5	1.1	4.7	0.75	3.4	0.55	62	100	35	ACS800-01-0001-2	R2
6.5	8.2	1.5	6	1.1	4.3	0.75	62	100	35	ACS800-01-0002-2	R2
8.5	10.8	1.5	7.7	1.5	5.7	1.1	62	100	35	ACS800-01-0003-2	R2
10.9	13.8	2.2	10.2	2.2	7.5	1.5	62	120	35	ACS800-01-0004-2	R2
13.9	17.6	3	12.7	3	9.3	2.2	62	140	35	ACS800-01-0005-2	R2
19	24	4	18	4	14	3	62	160	69	ACS800-01-0006-2	R3
25	32	5.5	24	5.5	19	4	62	200	69	ACS800-01-0009-2	R3
34	46	7.5	31	7.5	23	5.5	62	250	69	ACS800-01-0011-2	R3
44	62	11	42	11	32	7.5	62	340	103	ACS800-01-0016-2	R4
55	72	15	50	11	37	7.5	62	440	103	ACS800-01-0020-2	R4
72	86	18.5	69	18.5	49	11	65	530	250	ACS800-01-0025-2	R5
86	112	22	80	22	60	15	65	610	250	ACS800-01-0030-2	R5
103	138	30	94	22	69	18.5	65	810	250	ACS800-01-0040-2	R5
141	164	37	132	37	97	30	65	1190	405	ACS800-01-0050-2	R6
166	202	45	155	45	115	30	65	1190	405	ACS800-01-0060-2	R6
202	282	55	184	55	141	37	65	1440	405	ACS800-01-0070-2	R6
U_N = 400 V (Range 380-415 V). The power ratings are valid at nominal voltage 400 V.											
5.1	6.5	1.5	4.7	1.5	3.4	1.1	62	100	35	ACS800-01-0003-3	R2
6.5	8.2	2.2	5.9	2.2	4.3	1.5	62	120	35	ACS800-01-0004-3	R2
8.5	10.8	3	7.7	3	5.7	2.2	62	140	35	ACS800-01-0005-3	R2
10.9	13.8	4	10.2	4	7.5	3	62	160	35	ACS800-01-0006-3	R2
13.9	17.6	5.5	12.7	5.5	9.3	4	62	200	35	ACS800-01-0009-3	R2
19	24	7.5	18	7.5	14	5.5	62	250	69	ACS800-01-0011-3	R3
25	32	11	24	11	19	7.5	62	340	69	ACS800-01-0016-3	R3
34	46	15	31	15	23	11	62	440	69	ACS800-01-0020-3	R3
44	62	22	41	18.5	32	15	62	530	103	ACS800-01-0025-3	R4
55	72	30	50	22	37	18.5	62	610	103	ACS800-01-0030-3	R4
72	86	37	69	30	49	22	65	810	250	ACS800-01-0040-3	R5
86	112	45	80	37	60	30	65	990	250	ACS800-01-0050-3	R5
103	138	55	94	45	69	37	65	1190	250	ACS800-01-0060-3	R5
141	164	75	132	55	97	45	65	1440	405	ACS800-01-0070-3	R6
166	202	90	155	75	115	55	65	1940	405	ACS800-01-0100-3	R6
202	282	110	184	90	141	75	65	2310	405	ACS800-01-0120-3	R6

Ratings and dimensions

ACS800-01



ACS800 - 01 - XXXX - 5 + XXXX
7

Nominal ratings		No-overload use	Light-overload use		Heavy-duty use		Noise level	Heat dissipation	Air flow	Type code	Frame size
$I_{cont. max}$ A	I_{max} A	$P_{cont. max}$ kW	I_N A	P_N kW	I_{hd} A	P_{hd} kW	dBA	W	m ³ /h		
U_N = 500 V (Range 380-500 V). The power ratings are valid at nominal voltage 500 V.											
4.9	6.5	2.2	4.5	2.2	3.4	1.5	62	120	35	ACS800-01-0004-5	R2
6.2	8.2	3	5.6	3	4.2	2.2	62	140	35	ACS800-01-0005-5	R2
8.1	10.8	4	7.7	4	5.6	3	62	160	35	ACS800-01-0006-5	R2
10.5	13.8	5.5	10	5.5	7.5	4	62	200	35	ACS800-01-0009-5	R2
13.2	17.6	7.5	12	7.5	9.2	5.5	62	250	35	ACS800-01-0011-5	R2
19	24	11	18	11	13	7.5	62	340	69	ACS800-01-0016-5	R3
25	32	15	23	15	18	11	62	440	69	ACS800-01-0020-5	R3
34	46	18.5	31	18.5	23	15	62	530	69	ACS800-01-0025-5	R3
42	62	22	39	22	32	18.5	62	610	103	ACS800-01-0030-5	R4
48	72	30	44	30	36	22	62	810	103	ACS800-01-0040-5	R4
65	86	37	61	37	50	30	65	990	250	ACS800-01-0050-5	R5
79	112	45	75	45	60	37	65	1190	250	ACS800-01-0060-5	R5
96	138	55	88	55	69	45	65	1440	250	ACS800-01-0070-5	R5
124	164	75	115	75	88	55	65	1940	405	ACS800-01-0100-5	R6
157	202	90	145	90	113	75	65	2310	405	ACS800-01-0120-5	R6
180	282	110	163	110	141	90	65	2810	405	ACS800-01-0140-5	R6
U_N = 690 V (Range 525-690 V). The power ratings are valid at nominal voltage 690 V.											
13	14	11	11.5	7.5	8.5	5.5	62	300	103	ACS800-01-0011-7	R4
17	19	15	15	11	11	7.5	62	340	103	ACS800-01-0016-7	R4
22	28	18.5	20	15	15	11	62	440	103	ACS800-01-0020-7	R4
25	38	22	23	18.5	19	15	62	530	103	ACS800-01-0025-7	R4
33	44	30	30	22	22	18.5	62	610	103	ACS800-01-0030-7	R4
36	54	30	34	30	27	22	62	690	103	ACS800-01-0040-7	R4
51	68	45	46	37	34	30	65	840	250	ACS800-01-0050-7	R5
57	84	55	52	45	42	37	65	1010	250	ACS800-01-0060-7	R5
79	104	75	73	55	54	45	65	1220	405	ACS800-01-0070-7	R6
93	124	90	86	75	62	55	65	1650	405	ACS800-01-0100-7	R6
113	172	110	108	90	86	75	65	1960	405	ACS800-01-0120-7	R6

Enclosure

Degree of Protection:

IP21 (Standard)

IP55 (Optional)

Paint color:

NCS 1502-Y (RAL 90021/PMS 420C)

Frame size	IP21					IP55			
	H1 mm	H2 mm	W1 mm	Depth mm	Weight kg	H1 mm	W1 mm	Depth mm	Weight kg
R2	405	370 ^{A)}	165	226	9	528	263	241	16
R3	471	420 ^{A)}	173	265	14	528	263	273	18
R4	607	490 ^{A)}	240	274	26	774	377	278	33
R5	739	602 ^{A)}	265	286	34	775	377	308	51
R6	880	700 ^{A)}	300	399	67	923	420	420	77

H1 = Height with cable connection box
H2 = Height without cable connection box
W1 = Width of the standard unit

^{A)} ACS800-01 without cable connection box does not fulfill IP21 requirements.

Nominal Ratings:

$I_{cont. max}$: rated current available continuously without overloadability at 40°C.

I_{max} : maximum output current. Available for 10 s at start, otherwise as long as allowed by drive temperature. Note: max. motor shaft power is 150% P_{hd} .

Typical Ratings:

No-overload use

$P_{cont. max}$: typical motor power in no-overload use.

Light-overload use

I_N : continuous current allowing 110% I_N for 1min/ 5 min at 40°C.

P_N : typical motor power in light-overload use.

Heavy-duty use

I_{hd} : continuous current allowing 150% I_{hd} for 1min/ 5 min at 40°C.

P_{hd} : typical motor power in heavy-duty use.

The current ratings are the same regardless of the supply voltage within one voltage range.

The ratings apply at 40°C ambient temperature.

At higher temperatures (up to 50°C) the derating is 1% / 1°C.



Wall-mounted regenerative drives

ACS800-11, up to 110 kW

Wall-mounted regenerative drive

The ACS800-11 is a wall-mounted drive equipped with active supply unit. It offers a full performance regenerative drive in one compact package. The drive has extensive selection of inbuilt features and options. The power ratings start from 5.5 kW heavy-duty rating and go up to 110 kW continuous rating. It is available with IP21 protection degree.

Complete regenerative drive

The ACS800-11 offers you a complete regenerative drive in a single, compact wall-mounted package. All the functions of a regenerative drive, such as active supply unit, LCL line filter and charging circuitry, are integrated inside the drive. All this makes it possible to save installation time and space on the site, and also prevents installation mistakes as the drive is tested at the factory as a complete package.

Energy savings

The regenerative drive offers significant energy savings compared with other braking methods such as mechanical and resistor braking, as energy is fed back to the network. No external brake resistor is needed, which translates into simplified installation and no wasted heat.

Main standard hardware features

- Wall-mounting
- IP21 protection degree
- LCL line filter inside
- Active supply unit inside
- Long lifetime cooling fan and capacitors
- Extensive, programmable I/O with galvanically isolated inputs
- Three I/O and fieldbus extension slots inside
- Alphanumeric, multilingual control panel with start-up assistant feature
- Large power terminals allowing the use of a wide range of cable sizes

Options for ACS800-11

Inbuilt options:

- EMC filter for 1st environment, restricted distribution according to EN 61800-3 (category C2)
- EMC filter for 2nd environment, unrestricted distribution according to EN 61800-3 (category C3)
- Analog and digital I/O extension modules
- Fieldbus modules
- Pulse encoder interface module
- Prevention of an unexpected start-up
- Motion control and other control solution software

External options:

- Output filters
- Ethernet module



Ratings and dimensions

ACS800-11



Nominal rating		No-overload use	Light-overload use		Heavy-duty use		Noise level	Heat dissipation	Air flow	Type code	Frame size
$I_{cont.max}$ A	I_{max} A	$P_{cont.max}$ kW	I_N A	P_N kW	I_{hd} A	P_{hd} kW	dBA	W	m ³ /h		
$U_N = 230$ V (Range 208-240 V). The power ratings are valid at nominal voltage 230 V.											
34	52	7.5	32	7.5	26	5.5	70	505	350	ACS800-11-0011-2	R5
47	68	11	45	11	38	7.5	70	694	350	ACS800-11-0016-2	R5
59	90	15	56	15	45	11	70	910	350	ACS800-11-0020-2	R5
75	118	22	69	18.5	59	15	70	1099	350	ACS800-11-0025-2	R5
88	137	22	83	22	72	18.5	70	1315	350	ACS800-11-0030-2	R5
120	168	37	114	30	84	22	73	1585	405	ACS800-11-0040-2	R6
150	234	45	143	45	117	30	73	2125	405	ACS800-11-0050-2	R6
169	264	45	157	45	132	37	73	2530	405	ACS800-11-0060-2	R6
$U_N = 400$ V (Range 380-415 V). The power ratings are valid at nominal voltage 400 V.											
34	52	15	32	15	26	11	70	550	350	ACS800-11-0016-3	R5
38	61	18.5	36	18.5	34	15	70	655	350	ACS800-11-0020-3	R5
47	68	22	45	22	38	18.5	70	760	350	ACS800-11-0025-3	R5
59	90	30	56	30	45	22	70	1000	350	ACS800-11-0030-3	R5
72	118	37	69	37	59	30	70	1210	350	ACS800-11-0040-3	R5
86	137	45	83	45	65	30	70	1450	350	ACS800-11-0050-3	R5
120	168	55	114	55	88	45	73	1750	405	ACS800-11-0060-3	R6
150	234	75	143	75	117	55	73	2350	405	ACS800-11-0070-3	R6
165	264	90	157	75	132	75	73	2800	405	ACS800-11-0100-3	R6
$U_N = 500$ V (Range 380-500 V). The power ratings are valid at nominal voltage 500 V.											
31	52	18.5	29	18.5	25	15	70	655	350	ACS800-11-0020-5	R5
36	61	22	34	22	30	18.5	70	760	350	ACS800-11-0025-5	R5
47	68	30	45	30	37	22	70	1000	350	ACS800-11-0030-5	R5
58	90	37	55	37	47	30	70	1210	350	ACS800-11-0040-5	R5
70	118	45	67	45	57	37	70	1450	350	ACS800-11-0050-5	R5
82	130	55	78	45	62 ¹⁾	37	70	1750	350	ACS800-11-0060-5	R5
120	168	75	114	75	88	55	73	2350	405	ACS800-11-0070-5	R6
139	234	90	132	90	114	75	73	2800	405	ACS800-11-0100-5	R6
156	264	110	148 ²⁾	90	125	75	73	3400	405	ACS800-11-0120-5	R6
$U_N = 690$ V (Range 525-690 V). The power ratings are valid at nominal ratings 690 V.											
57 ³⁾	86	55	54	45	43	37	76	1750	405	ACS800-11-0060-7	R6
79	120	75	75	55	60	55	76	2350	405	ACS800-11-0070-7	R6
93 ⁴⁾	142	90	88	75	71	55	76	2800	405	ACS800-11-0100-7	R6

Enclosure
Degree of Protection:
IP21 (Standard)
Paint color:
NCS 1502-Y (RAL 90021/PMS 420C)

Frame size	IP21			
	Height mm	Width mm	Depth mm	Weight kg
R5	816	265	390	62
R6	970	300	440	100

Note:

- ¹⁾ 65 A is allowed at 460 V.
- ²⁾ 156 A is allowed at 460 V.
- ³⁾ 62 A is allowed at 575 V.
- ⁴⁾ 99 A is allowed at 575 V.

Nominal Ratings:

$I_{cont.max}$: rated current available continuously without overloadability at 40°C.

I_{max} : maximum output current. Available for 10 s at start, otherwise as long as allowed by drive temperature. Note: max. motor shaft power is 150% P_{hd} .

Typical Ratings:

No-overload use

$P_{cont.max}$: typical motor power in no-overload use.

Light-overload use

I_N : continuous current allowing 110% I_N for 1min/ 5 min at 40°C.

P_N : typical motor power in light-overload use.

Heavy-duty use

I_{hd} : continuous current allowing 150% I_{hd} for 1min/ 5 min at 40°C.

P_{hd} : typical motor power in heavy-duty use.

The current ratings are the same regardless of the supply voltage within one voltage range.

The ratings apply at 40°C ambient temperature.

At higher temperatures (up to 50°C) the derating is 1% / 1°C.

For sine filter selections and ratings, contact ABB.

Wall-mounted low harmonic drives

ACS800-31, up to 110 kW



Easy low harmonic solution

There is increasing concern among end users and power companies about the harmful effects of harmonics. Harmonic distortion may disturb or even damage sensitive equipment connected in the same environment. Harmonics also cause additional losses in the network. Harmonic standards are thus becoming stricter and there is a growing demand for low harmonic solutions.

ABB's low harmonic drives offer an easy low harmonic solution incorporated in the drive. The solution to overcome harmonic issues simply comes with the drive without the need for additional filtering equipment or complicated multi-pulse transformer arrangements.

Compact solution

The ACS800-31 is low harmonic drive in a single, complete wall-mounted package. It has an active supply unit and low harmonic line filter integrated in the drive resulting in less cabling and installation work on site. This compact drive package itself has extremely low line harmonics and thus meets the strictest harmonic standards without any need for additional filtering equipment. Due to the active supply unit it always operates with power factor 1.

The power ratings of the ACS800-31 start from 5.5 kW heavy duty rating and go up to 110 kW continuous load rating. It is available in the IP21 protection degree. In line with the ACS800 series, an extensive range of inbuilt options are available including EMC filters and extension modules for additional I/O.

Main standard hardware features

- Wall-mounting
- IP21 protection degree
- Active supply unit inside
- Low harmonic filter inside
- Long lifetime cooling fan and capacitors
- Extensive, programmable I/O with galvanically isolated inputs
- Three I/O and fieldbus extension slots inside
- Alphanumeric, multilingual control panel with start-up assistant feature
- Large power terminals allowing the use of a wide range of cable sizes

Options for ACS800-31

Inbuilt options:

- EMC filter for 1st environment, restricted distribution according to EN 61800-3 (category C2)
- EMC filter for 2nd environment, unrestricted distribution according to EN 61800-3 (category C3)
- Analog and digital I/O extension modules
- Fieldbus modules
- Pulse encoder interface module

External options:

- Output filters
- Brake chopper and resistor
- Ethernet module



Ratings and dimensions

ACS800-31



ACS800	-	31	-	XXXX	-	2 3 5 7	+	XXXX
--------	---	----	---	------	---	------------------	---	------

Nominal ratings		No-overload use	Light-overload use		Heavy-duty use		Noise level	Heat dissipation	Air flow	Type code	Frame size
$I_{cont.max}$ A	I_{max} A	$P_{cont.max}$ kW	I_N A	P_N kW	I_{hd} A	P_{hd} kW	dBA	W	m ³ /h		
$U_N = 230$ V (Range 208-240 V). The power ratings are valid at nominal voltage 230 V.											
34	52	7.5	32	7.5	26	5.5	70	505	350	ACS800-31-0011-2	R5
47	68	11	45	11	38	7.5	70	694	350	ACS800-31-0016-2	R5
59	90	15	56	15	45	11	70	910	350	ACS800-31-0020-2	R5
75	118	22	69	18.5	59	15	70	1099	350	ACS800-31-0025-2	R5
88	137	22	83	22	72	18.5	70	1315	350	ACS800-31-0030-2	R5
120	168	37	114	30	84	22	73	1585	405	ACS800-31-0040-2	R6
150	234	45	143	45	117	30	73	2125	405	ACS800-31-0050-2	R6
169	264	45	157	45	132	37	73	2530	405	ACS800-31-0060-2	R6
$U_N = 400$ V (Range 380-415 V). The power ratings are valid at nominal voltage 400 V.											
34	52	15	32	15	26	11	70	550	350	ACS800-31-0016-3	R5
38	61	18.5	36	18.5	34	15	70	655	350	ACS800-31-0020-3	R5
47	68	22	45	22	38	18.5	70	760	350	ACS800-31-0025-3	R5
59	90	30	56	30	45	22	70	1000	350	ACS800-31-0030-3	R5
72	118	37	69	37	59	30	70	1210	350	ACS800-31-0040-3	R5
86	137	45	83	45	65	30	70	1450	350	ACS800-31-0050-3	R5
120	168	55	114	55	88	45	73	1750	405	ACS800-31-0060-3	R6
150	234	75	143	75	117	55	73	2350	405	ACS800-31-0070-3	R6
165	264	90	157	75	132	75	73	2800	405	ACS800-31-0100-3	R6
$U_N = 500$ V (Range 380-500 V). The power ratings are valid at nominal voltage 500 V.											
31	52	18.5	29	18.5	25	15	70	655	350	ACS800-31-0020-5	R5
36	61	22	34	22	30	18.5	70	760	350	ACS800-31-0025-5	R5
47	68	30	45	30	37	22	70	1000	350	ACS800-31-0030-5	R5
58	90	37	55	37	47	30	70	1210	350	ACS800-31-0040-5	R5
70	118	45	67	45	57	37	70	1450	350	ACS800-31-0050-5	R5
82	130	55	78	45	62 ¹⁾	37	70	1750	350	ACS800-31-0060-5	R5
120	168	75	114	75	88	55	73	2350	405	ACS800-31-0070-5	R6
139	234	90	132	90	114	75	73	2800	405	ACS800-31-0100-5	R6
156	264	110	148 ²⁾	90	125	75	73	3400	405	ACS800-31-0120-5	R6
$U_N = 690$ V (Range 525-690 V). The power ratings are valid at nominal voltage 690 V.											
57 ³⁾	86	55	54	45	43	37	76	1750	405	ACS800-31-0060-7	R6
79	120	75	75	55	60	55	76	2350	405	ACS800-31-0070-7	R6
93 ⁴⁾	142	90	88	75	71	55	76	2800	405	ACS800-31-0100-7	R6

Enclosure
Degree of Protection:
IP21 (Standard)
Paint color:
NCS 1502-Y (RAL 90021/PMS 420C)

Frame size	IP21			
	Height mm	Width mm	Depth mm	Weight kg
R5	816	265	390	62
R6	970	300	440	100

Note:

- ¹⁾ 65 A is allowed at 460 V.
- ²⁾ 156 A is allowed at 460 V.
- ³⁾ 62 A is allowed at 575 V.
- ⁴⁾ 99 A is allowed at 575 V.

Nominal Ratings:

$I_{cont.max}$: rated current available continuously without overloadability at 40°C.

I_{max} : maximum output current. Available for 10 s at start, otherwise as long as allowed by drive temperature. Note: max. motor shaft power is 150% P_{hd} .

Typical Ratings:

No-overload use

$P_{cont.max}$: typical motor power in no-overload use.

Light-overload use

I_N : continuous current allowing 110% I_N for 1min/ 5 min at 40°C.

P_N : typical motor power in light-overload use.

Heavy-duty use

I_{hd} : continuous current allowing 150% I_{hd} for 1min/ 5 min at 40°C.

P_{hd} : typical motor power in heavy-duty use.

The current ratings are the same regardless of the supply voltage within one voltage range.

The ratings apply at 40°C ambient temperature.

At higher temperatures (up to 50°C) the derating is 1% / 1°C.

For sine filter selections and ratings, contact ABB.



Free-standing drives

ACS800-02, up to 560 kW

Compact and complete drive

The ACS800-02 single drive is a unique, extremely compact bookshelf-style unit with a new innovative free-standing enclosure. The power ratings start from 45 kW heavy duty rating and go up to 560 kW continuous load rating. It is available in IP21 protection degree.

Fits anywhere

The ACS800-02 drive is extremely compact without sacrificing user-friendliness. When using bookshelf mounting, even side-by-side installation is possible. In addition to bookshelf mounting, the ACS800-02 offers the possibility for flat type (sideways) mounting, making it possible to optimize depth instead of width.

Everything inside

The ACS800-02 has an extensive selection of inbuilt features and options. Standard features include a choke for harmonic filtering and drive protection, extensive and flexible I/O, user-friendly control panel with Start-up Assistant feature and a silent, long lifetime cooling fan.

Inbuilt options include EMC filters, brake chopper, common mode filter for motor protection and extension modules for additional I/O, fieldbus and pulse encoder. An enclosure extension is also available for incoming apparatus, further enhancing the versatility of the drive.



Main standard hardware features

- Free-standing
- IP21 protection degree
- Very narrow bookshelf design
- Two mounting directions as standard enabling optimization of depth
- Harmonic filtering choke inside
- Input rectifier protection
- Long lifetime cooling fan and capacitors
- Extensive, programmable I/O with galvanically isolated inputs
- Three I/O and fieldbus extension slots inside
- Alphanumeric, multilingual control panel with start-up assistant feature
- Large power terminals allowing the use of a wide range of cable sizes

Options for ACS800-02

Inbuilt options:

- Brake chopper
- EMC filter for 1st environment, restricted distribution according to EN 61800-3 (category C2)
- EMC filter for 2nd environment, unrestricted distribution according to EN 61800-3 (category C3)
- Analog and digital I/O extension modules
- Fieldbus modules
- Pulse encoder interface module
- Common mode filters for motor protection

Options available with enclosure extension:

- Fuse switch
- Contactor with emergency stop push button
- 1 or 2 thermistor relays
- 3 Pt100 relays
- Cable top entry and exit
- Customer terminal block

External options:

- Brake resistor
- Output filters
- Ethernet module



Ratings and dimensions

ACS800-02



Nominal ratings		No-overload use	Light-overload use		Heavy-duty use		Noise level	Heat dissipation	Air flow	Type code	Frame size
$I_{cont. max}$ A	I_{max} A	$P_{cont. max}$ kW	I_N A	P_N kW	I_{hd} A	P_{hd} kW	dBA	W	m ³ /h		
$U_N = 230$ V (Ranges 208-240 V). The power ratings are valid at nominal voltage 230 V.											
214	326	55	211	55	170	45	71	2900	540	ACS800-02-0080-2	R7
253	404	75	248	75	202	55	71	3450	540	ACS800-02-0100-2	R7
295	432	90	290	90	240 ¹⁾	55	71	4050	540	ACS800-02-0120-2	R7
405	588	110	396	110	316	90	72	5300	1220	ACS800-02-0140-2	R8
447	588	132	440	132	340	90	72	6100	1220	ACS800-02-0170-2	R8
528	588	160	516	160	370	110	72	6700	1220	ACS800-02-0210-2	R8
613	840	160	598	160	480	132	72	7600	1220	ACS800-02-0230-2	R8
693	1017	200	679	200	590 ²⁾	160	72	7850	1220	ACS800-02-0260-2	R8
720	1017	200	704	200	635 ³⁾	200	72	8300	1220	ACS800-02-0300-2	R8
$U_N = 400$ V (Ranges 380-415 V). The power ratings are valid at nominal voltage 400 V.											
206	326	110	202	110	163	90	71	3000	540	ACS800-02-0140-3	R7
248	404	132	243	132	202	110	71	3650	540	ACS800-02-0170-3	R7
289	432	160	284	160	240 ⁴⁾	132	71	4300	540	ACS800-02-0210-3	R7
445	588	200	440	200	340	160	72	6600	1220	ACS800-02-0260-3	R8
521	588	250	516	250	370	200	72	7150	1220	ACS800-02-0320-3	R8
602	840	315	590	315	477	250	72	8100	1220	ACS800-02-0400-3	R8
693	1017	355	679	355	590 ²⁾	315	72	8650	1220	ACS800-02-0440-3	R8
720	1017	400	704	400	635 ³⁾	355	72	9100	1220	ACS800-02-0490-3	R8
$U_N = 500$ V (Ranges 380-500 V). The power ratings are valid at nominal voltage 500 V.											
196	326	132	192	132	162	110	71	3000	540	ACS800-02-0170-5	R7
245	384	160	240	160	192	132	71	3800	540	ACS800-02-0210-5	R7
289	432	200	284	200	224	160	71	4500	540	ACS800-02-0260-5	R7
440	588	250	435	250	340	200	72	6850	1220	ACS800-02-0320-5	R8
515	588	315	510	315	370	250	72	7800	1220	ACS800-02-0400-5	R8
550	840	355	545	355	490	315	72	7600	1220	ACS800-02-0440-5	R8
602	840	400	590	400	515 ²⁾	355	72	8100	1220	ACS800-02-0490-5	R8
684	1017	450	670	450	590 ²⁾	400	72	9100	1220	ACS800-02-0550-5	R8
718	1017	500	704	500	632 ³⁾	450	72	9700	1220	ACS800-02-0610-5	R8
$U_N = 690$ V (Ranges 525-690 V). The power ratings are valid at nominal voltage 690 V.											
134	190	132	125	110	95	90	71	2800	540	ACS800-02-0140-7	R7
166	263	160	155	132	131	110	71	3550	540	ACS800-02-0170-7	R7
166/203 ⁵⁾	294	160	165/195 ⁵⁾	160	147	132	71	4250	540	ACS800-02-0210-7	R7
175/230 ⁵⁾	326	160/200 ⁵⁾	175/212 ⁵⁾	160/200 ⁵⁾	163	160	71	4800	540	ACS800-02-0260-7	R7
315	433	315	290	250	216	200	72	6150	1220	ACS800-02-0320-7	R8
353	548	355	344	315	274	250	72	6650	1220	ACS800-02-0400-7	R8
396	656	400	387	355	328	315	72	7400	1220	ACS800-02-0440-7	R8
445	775	450	426	400	387	355	72	8450	1220	ACS800-02-0490-7	R8
488	853	500	482	450	426	400	72	8300	1220	ACS800-02-0550-7	R8
560	964	560	537	500	482	450	72	9750	1220	ACS800-02-0610-7	R8

Enclosure
Degree of Protection:
IP21 (Standard)
Paint color:
NCS 1502-Y (RAL 90021/PMS 420C)

Frame size	IP21					
	Height mm	Width 1 mm	Width 2 mm	Depth mm	Width mm	Weight with enclosure extension *) kg
R7	1507	250 ^{A)}	602	524 ^{A) B)}	110	234
R8	2024	347 ^{A)}	793	622 ^{A) B)}	240	450

Width 1 = Width of the standard unit
Width 2 = Width with the enclosure extension

- A) The dimensions apply to bookshelf mounting. In flat type mounting the width and depth change places.
- B) With enclosure extension the depth is increased by 25 mm due to the switch fuse handle.
- 7) Weights are for the basic configuration with switch fuse, but without contactor and other options.

Nominal Ratings:
 $I_{cont. max}$: rated current available continuously without overloadability at 40°C.

I_{max} : maximum output current. Available for 10 s at start, otherwise as long as allowed by drive temperature. Note: max. motor shaft power is 150% P_{hd} .

Typical Ratings:
No-overload use
 $P_{cont. max}$: typical motor power in no-overload use.

Light-overload use
 I_N : continuous current allowing 110% I_N for 1 min / 5 min at 40°C.

P_N : typical motor power in light-overload use.

Heavy-duty use
 I_{hd} : continuous current allowing 150% I_{hd} for 1 min / 5 min at 40°C.

P_{hd} : typical motor power in heavy-duty use.

The current ratings are the same regardless of the supply voltage within one voltage range.

The ratings apply at 40°C ambient temperature.
At higher temperatures (up to 50°C) the derating is 1% / 1°C.

- Notes:**
- 1) 50% overload available if $T_{amb} < 35^\circ\text{C}$. If $T_{amb} = 40^\circ\text{C}$, max overload is 45%.
 - 2) 50% overload available if $T_{amb} < 30^\circ\text{C}$. If $T_{amb} = 40^\circ\text{C}$, max overload is 40%.
 - 3) 50% overload available if $T_{amb} < 20^\circ\text{C}$. If $T_{amb} = 40^\circ\text{C}$, max overload is 30%.
 - 4) 50% overload available if $T_{amb} < 25^\circ\text{C}$. If $T_{amb} = 40^\circ\text{C}$, max overload is 37%.
 - 5) Higher value available if output frequency is above 41 Hz.



Cabinet-built drives

ACS800-07, up to 2800 kW

Customized solutions

The ACS800-07 is built in a robust cabinet designed for heavy industrial applications.

The ACS800-07 offers a wide variety of standardized configurations to adapt to different application requirements, from line contactor to prevention of unexpected motor start, or ATEX-approved motor protections.

If your application requires more, ABB's application engineering services can add special features to the standard product such as an additional cabinet for customer specific devices to ensure exact suitability for the application.

Smart module concept

The drives up to 560 kW are based on a compact single module including rectifier and inverter. Larger drives consist of separate rectifier and inverter modules, which have plug-in power connectors providing easy maintenance and redundancy with parallel connected units. If one module becomes defective, the drive can continue running with reduced power after disconnecting the faulty module. The rectifier module of the larger drives provides 6- or 12-pulse operation.

Extensive range of features

The ACS800-07 has an extensive range of inbuilt features and options. Typical option choices include extended I/O and fieldbus options, line contactor, EMC filtering, common mode filtering and du/dt (voltage rise) filtering, all mountable within the single cabinet.

Main standard features

- Compact design
- IP21 protection degree
- Inbuilt harmonic filtering choke
- Du/dt filters (in frame sizes nxR8i)

- Common mode filters for motor protection (in frame sizes nxR8i)
- Main switch with fuses (in frame sizes R6-R8)
- Main switch (in frame sizes nxR8i)
- Extensive, programmable I/O
- Inputs galvanically isolated
- 6- or 12-pulse operation (in frame sizes nxR8i)
- Long lifetime cooling fan and capacitors
- I/O and fieldbus extension slots inside
- Alphanumeric multilingual control panel with start-up assistant feature
- EMC filter for 2nd environment, unrestricted distribution according to EN 61800-3 (in frame sizes nxR8i) (category C3)

Accessories for ACS800-07

- Analog and digital I/O extension modules
- ATEX approved motor protection
- Brake chopper and resistor
- Cabinet heater
- Common mode filters for motor protection (in frame sizes R7-R8)
- Customer terminal block
- du/dt filters (in frame sizes R6-R8)
- Earth fault monitoring for unearthed network
- EMC filter for 1st environment, restricted distribution according to EN 61800-3 (category C2)
- EMC filter for 2nd environment, unrestricted distribution according to EN 61800-3 (in frame sizes R6-R8) (category C3)
- Fieldbus modules
- IP22, IP42, IP54 or IP54R protection degrees
- Line contactor with emergency stop push button
- Line fuses with main switch and input terminal cubicle (in frame size nxR8i)
- Marine construction
- Output for fan motor
- Pulse encoder interface module
- Prevention of unexpected start up of motor
- Top entry and exit of cables
- 1 or 2 thermistor relays
- 3, 5 or 8 Pt100 relays

Plus tailor made options through ABB's application engineering.

Cabinet-built drives

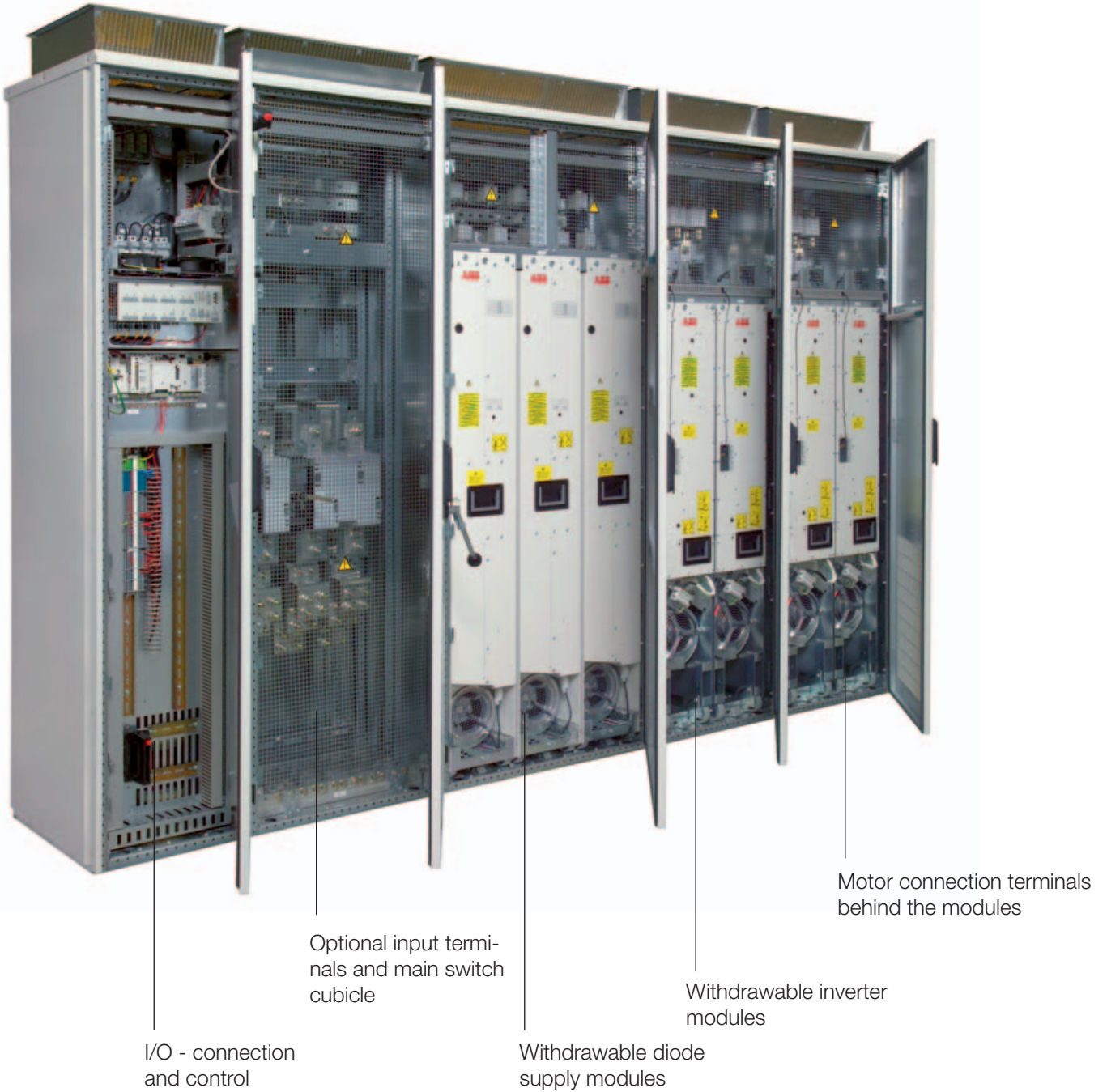

ACS800-07-3190-7 2600 kW drive

Diode supply and inverter units of nxR8i drives are on wheels providing quick and easy maintenance.

Ratings and dimensions

ACS800-07



ACS800 - 07 - XXXX - 3 + XXXX
5

Nominal ratings		No-overload use	Light-overload use		Heavy-duty use		Noise level	Heat dissipation	Air flow	Type code	Frame size
I _{cont. max} A	I _{max} A	P _{cont. max} kW	I _N A	P _N kW	I _{hd} A	P _{hd} kW	dBA	kW	m ³ /h		
U_N = 400 V (Range 380-415 V). The power ratings are valid at nominal voltage 400 V.											
141	164	75	132	55	97	45	63	1.44	405	ACS800-07-0070-3	R6
166	202	90	155	75	115	55	63	1.94	405	ACS800-07-0100-3	R6
202	282	110	184	90	141	75	63	2.31	405	ACS800-07-0120-3	R6
206	326	110	202	110	163	90	71	3.00	540	ACS800-07-0140-3	R7
248	404	132	243	132	202	110	71	3.65	540	ACS800-07-0170-3	R7
289	432	160	284	160	240 ¹⁾	132	71	4.30	540	ACS800-07-0210-3	R7
445	588	200	440	200	340	160	72	6.60	1220	ACS800-07-0260-3	R8
521	588	250	516	250	370	200	72	7.15	1220	ACS800-07-0320-3	R8
602	840	315	590	315	477	250	72	8.10	1220	ACS800-07-0400-3	R8
693	1017	355	679	355	590 ²⁾	315	72	8.65	1220	ACS800-07-0440-3	R8
720	1017	400	704	400	635 ³⁾	355	72	9.00	1220	ACS800-07-0490-3	R8
879	1315	500	844	500	657	400	73	13.0	3120	ACS800-07-0610-3	1xD4 + 2xR8i
1111	1521	630	1067	630	831	450	74	17.2	3840	ACS800-07-0770-3	2xD4 + 2xR8i
1255	1877	710	1205	710	939	500	74	18.5	3840	ACS800-07-0870-3	2xD4 + 2xR8i
1452	1988	800	1394	800	1086	630	74	23.9	3840	ACS800-07-1030-3	2xD4 + 2xR8i
1770	2648	1000	1699	1000	1324	710	75	27.5	5040	ACS800-07-1230-3	2xD4 + 3xR8i
2156	2951	1200	2070	1200	1613	900	76	35.4	5760	ACS800-07-1540-3	3xD4 + 3xR8i
2663	3894	1450	2556	1450	1992	1120	76	42.7	6960	ACS800-07-1850-3	3xD4 + 4xR8i
U_N = 500 V (Range 380-500 V). The power ratings are valid at nominal voltage 500 V.											
124	164	75	115	75	88	55	63	1.94	405	ACS800-07-0100-5	R6
157	202	90	145	90	113	75	63	2.31	405	ACS800-07-0120-5	R6
180	282	110	163	110	141	90	63	2.81	405	ACS800-07-0140-5	R6
196	326	132	192	132	162	110	71	3.00	540	ACS800-07-0170-5	R7
245	384	160	240	160	192	132	71	3.80	540	ACS800-07-0210-5	R7
289	432	200	284	200	224	160	71	4.50	540	ACS800-07-0260-5	R7
440	588	250	435	250	340	200	72	6.85	1220	ACS800-07-0320-5	R8
515	588	315	510	315	370	250	72	7.80	1220	ACS800-07-0400-5	R8
550	840	355	545	355	490	315	72	7.60	1220	ACS800-07-0440-5	R8
602	840	400	590	400	515 ²⁾	355	72	8.10	1220	ACS800-07-0490-5	R8
684	1017	450	670	450	590 ²⁾	400	72	9.10	1220	ACS800-07-0550-5	R8
718	1017	500	704	500	632 ³⁾	450	72	9.70	1220	ACS800-07-0610-5	R8
883	1321	630	848	630	660	500	73	14.0	3120	ACS800-07-0760-5	1xD4 + 2xR8i
1050	1524	710	1008	710	785	560	74	17.2	3840	ACS800-07-0910-5	2xD4 + 2xR8i
1258	1882	900	1208	900	941	630	74	19.9	3840	ACS800-07-1090-5	2xD4 + 2xR8i
1372	1991	1000	1317	1000	1026	710	74	23.8	3840	ACS800-07-1210-5	2xD4 + 2xR8i
1775	2655	1250	1704	1200	1328	900	75	29.4	5040	ACS800-07-1540-5	2xD4 + 3xR8i
2037	2956	1450	1956	1400	1524	1120	76	35.0	5760	ACS800-07-1820-5	3xD4 + 3xR8i
2670	3901	1900	2563	1850	1997	1400	76	45.4	6960	ACS800-07-2310-5	3xD4 + 4xR8i

Ratings and dimensions

ACS800-07



ACS800 - 07 - XXXX - 7 + XXXX

Nominal ratings		No-overload use	Light-overload use		Heavy-duty use		Noise level	Heat dissipation	Air flow	Type code	Frame size
$I_{cont. max}$ A	I_{max} A	$P_{cont. max}$ kW	I_N A	P_N kW	I_{hd} A	P_{hd} kW	dBA	kW	m ³ /h		
$U_N = 690$ V (Range 525-690 V). The power ratings are valid at nominal voltage 690 V.											
79	104	75	73	55	54	45	63	1.22	405	ACS800-07-0070-7	R6
93	124	90	86	75	62	55	63	1.65	405	ACS800-07-0100-7	R6
113	172	110	108	90	86	75	65	1.96	405	ACS800-07-0120-7	R6
134	190	132	125	110	95	90	71	2.80	540	ACS800-07-0140-7	R7
166	263	160	155	132	131	110	71	3.55	540	ACS800-07-0170-7	R7
166/203 ^{d)}	294	160	165/195 ^{d)}	160	147	132	71	4.25	540	ACS800-07-0210-7	R7
175/230 ^{d)}	326	160/200 ^{d)}	175/212 ^{d)}	160/200 ^{d)}	163	160	71	4.80	540	ACS800-07-0260-7	R7
315	433	315	290	250	216	200	72	6.15	1220	ACS800-07-0320-7	R8
353	548	355	344	315	274	250	72	6.65	1220	ACS800-07-0400-7	R8
396	656	400	387	355	328	315	72	7.40	1220	ACS800-07-0440-7	R8
445	775	450	426	400	387	355	72	8.45	1220	ACS800-07-0490-7	R8
488	853	500	482	450	426	400	72	8.30	1220	ACS800-07-0550-7	R8
560	964	560	537	500	482	450	72	9.75	1220	ACS800-07-0610-7	R8
628	939	630	603	630	470	500	73	13.9	3120	ACS800-07-0750-7	1xD4 + 2xR8i
729	1091	710	700	710	545	560	73	17.1	3120	ACS800-07-0870-7	1xD4 + 2xR8i
885	1324	800	850	800	662	630	73	18.4	3120	ACS800-07-1060-7	1xD4 + 2xR8i
953	1426	900	915	900	713	710	74	20.8	3840	ACS800-07-1160-7	2xD4 + 2xR8i
1258	1882	1200	1208	1200	941	900	75	27.0	5040	ACS800-07-1500-7	2xD4 + 3xR8i
1414	2115	1400	1357	1400	1058	1000	75	32.5	5040	ACS800-07-1740-7	2xD4 + 3xR8i
1774	2654	1700	1703	1700	1327	1250	76	40.1	6240	ACS800-07-2120-7	2xD4 + 4xR8i
1866	2792	1900	1791	1800	1396	1400	76	43.3	6960	ACS800-07-2320-7	3xD4 + 4xR8i
2321	3472	2300	2228	2200	1736	1600	77	51.5	8160	ACS800-07-2900-7	3xD4 + 5xR8i
2665	3987	2600	2558	2500	1993	1900	78	58.0	9360	ACS800-07-3190-7	3xD4 + 6xR8i
2770	4144	2800	2659	2700	2072	2100	78	63.6	10080	ACS800-07-3490-7	4xD4 + 6xR8i

Enclosure

Degree of Protection:
IP21 (Standard)
IP22, IP42, IP54, IP54R (Optional)
Paint color:
Light beige RAL 7035 semi-gloss

Frame size	Width mm	6-pulse width with switch and fuses mm	12-pulse width with switch and fuses mm	Height IP21/22/42 mm	Height IP54 mm	Depth ^{D)} mm	Depth top exit ^{D)} mm	Weight kg	Weight with switch and fuses kg
R6	-	430 ^{A)}	-	2130	2315	646	646	-	300
R7	-	830 ^{B)}	-	2130	2315	646	646	-	400
R8	-	830 ^{C)}	-	2130	2315	646	646	-	500
1xD4 + 2xR8i	1330	1730	1830	2130	2315	646	776 ^{E)}	890	1100
2xD4 + 2xR8i	1630	2130	2130	2130	2315	646	776 ^{E)}	1200	1410
2xD4 + 3xR8i	1830	2330	2330	2130	2315	646	776 ^{E)}	1350	1560
2xD4 + 4xR8i	2230	2730	2730	2130	2315	646	776 ^{E)}	1680	1890
3xD4 + 3xR8i	2030	2630	2630	2130	2315	646	776 ^{E)}	1540	1800
3xD4 + 4xR8i	2430	3030	3030	2130	2315	646	776 ^{E)}	1870	2130
3xD4 + 5xR8i	2630	3230	3230	2130	2315	646	776 ^{E)}	2020	2280
3xD4 + 6xR8i	2830	3430	3430	2130	2315	646	776 ^{E)}	2170	2430
4xD4 + 6xR8i	3230	3830	3830	2130	2315	646	776 ^{E)}	2520	2940

- ^{A)} 630 mm for types ACS800-07-0120-3 and 0140-5 if equipped with du/dt filter.
- ^{B)} 1030 mm if equipped with 1st environment EMC filter.
- ^{C)} 1230 mm if equipped with 1st environment EMC filter.
- ^{D)} The depth without the handle.
- ^{E)} The depth is 646 mm if common motor terminal is used.

Nominal Ratings:

$I_{cont. max}$: rated current available continuously without overloadability at 40°C.

I_{max} : maximum output current. Available for 10 s at start, otherwise as long as allowed by drive temperature. Note: max. motor shaft power is 150% P_{hd} .

Typical Ratings:

No-overload use

$P_{cont. max}$: typical motor power in no-overload use.

Light-overload use

I_N : continuous current allowing 110% I_N for 1 min / 5 min at 40°C.

P_N : typical motor power in light-overload use.

Heavy-duty use

I_{hd} : continuous current allowing 150% I_{hd} for 1 min / 5 min at 40°C.

P_{hd} : typical motor power in heavy-duty use.

The current ratings are the same regardless of the supply voltage within one voltage range.

The ratings apply at 40°C ambient temperature. At higher temperatures (up to 50°C) the derating is 1% / 1°C.

Notes:

- ¹⁾ 50% overload available if $T_{amb} < 25^\circ\text{C}$. If $T_{amb} = 40^\circ\text{C}$, max overload is 37%.
- ²⁾ 50% overload available if $T_{amb} < 30^\circ\text{C}$. If $T_{amb} = 40^\circ\text{C}$, max overload is 40%.
- ³⁾ 50% overload available if $T_{amb} < 20^\circ\text{C}$. If $T_{amb} = 40^\circ\text{C}$, max overload is 30%.
- ⁴⁾ Higher value available if output frequency is above 41 Hz.

Cabinet-built regenerative drives

ACS800-17, up to 2500 kW



Complete regenerative drive

The ACS800-17 offers you a complete regenerative drive in a single, compact cabinet-built package. The drive includes everything that is needed for regenerative operation, including line filter. The active supply unit allows full power flow both in motoring and generating modes.

Energy savings

Compared with other braking methods such as mechanical and resistor braking, the energy savings can be significant with the ACS800-17. The braking energy is returned to network, not wasted as heat. Handling of waste heat may also be a problem if braking power is significant. As no external braking devices are needed with the ACS800-17, installation work is simpler and the space requirement for installation is less.

High performance

The ACS800-17 is especially suitable for demanding applications. Transition between motoring and generating is fast due to the patented DTC control method. The active supply unit is able to boost output voltage, which guarantees full motor voltage even when the supply voltage is below nominal.

The active supply unit combined with the DTC control can even compensate for fast variations in line voltage. There is no risk of fuse blow or component damage due to voltage drops in the network.

Extensive range of features

Adaptation to different application requirements is possible by selecting from a wide range of standardized configurations. The cabinet-built drive series enables having a significant amount of features and accessories as inbuilt options.

Main standard features

- Compact design
- IP21 protection degree
- LCL line filter inside
- EMC filter for 2nd environment, unrestricted distribution according to EN 61800-3 (option in frame size R6) (category C3)
- Main switch with aR fuses (in frame sizes R6-R8i)
- Line contactor (in frame sizes R7i-R8i, option in frame size R6)
- Withdrawable air circuit breaker (in frame size nxR8i)
- Common mode filters for motor protection (in frame sizes R7i-nxR8i)
- du/dt filters (in frame size nxR8i)
- Coated boards
- Extensive, programmable I/O
- Long lifetime cooling fan and capacitors
- Inputs galvanically isolated
- I/O and fieldbus extension slots inside
- Alphanumeric multilingual control panel with start-up assistant feature

Accessories for the ACS800-17

- Analogue and digital I/O extension modules
- ATEX approved motor protection
- Cabinet heater
- Customer terminal block/du/dt filters (in frame sizes R6-R8i)
- Earth fault monitoring for unearthed network
- EMC filter for 1st environment, restricted distribution according to EN 61800-3 (category C2)
- Fieldbus modules
- IP22, IP42, IP54 or IP54R protection degrees
- Emergency stop, category 0 or 1
- Marine construction
- Output for motor fan
- Pulse encoder interface module
- Prevention of unexpected start up of motor
- Top entry and exit of cables
- 1 or 2 thermistor relays
- 3, 5 or 8 Pt100 relays

Plus tailor made accessories through ABB's application engineering.



Ratings and dimensions

ACS800-17

ACS800 - 17 - XXXX - 3 + XXXX
5

Nominal ratings		No-overload use	Light-overload use		Heavy-duty use		Noise level	Heat dissipation	Air flow	Type code	Frame size
I _{cont. max} A	I _{max} A	P _{cont. max} kW	I _N A	P _N kW	I _{hd} A	P _{hd} kW	dBA	kW	m ³ /h		
U_N = 400 V (Range 380-415 V). The power ratings are valid at nominal voltage 400 V.											
120	168	55	114	55	88	45	73	1.8	500	ACS800-17-0060-3	R6
150	234	75	142	75	117	55	73	2.4	500	ACS800-17-0070-3	R6
165	264	90	157	75	132	75	73	2.8	500	ACS800-17-0100-3	R6
202	293	110	194	90	151	75	74	6	1300	ACS800-17-0140-3	R7i
250	363	132	240	132	187	90	74	7	1300	ACS800-17-0170-3	R7i
292	400	160	280	160	218	110	75	7	3160	ACS800-17-0210-3	R8i
370	506	200	355	200	277	132	75	9	3160	ACS800-17-0260-3	R8i
469	642	250	450	250	351	200	75	11	3160	ACS800-17-0320-3	R8i
565	773	315	542	315	423	250	75	14	3160	ACS800-17-0390-3	R8i
704	963	400	675	355	526	250	75	19	3160	ACS800-17-0490-3	R8i
919	1258	500	882	500	688	355	77	22	6400	ACS800-17-0640-3	2xR8i
1111	1521	630	1067	630	831	450	77	28	6400	ACS800-17-0770-3	2xR8i
1379	1888	800	1324	710	1031	560	77	36	6400	ACS800-17-0960-3	2xR8i
1535	2102	900	1474	800	1149	630	78	39	10240	ACS800-17-1070-3	3xR8i
1978	2707	1200	1899	1100	1479	800	78	51	10240	ACS800-17-1370-3	3xR8i
2610	3573	1600	2506	1400	1953	1100	79	67	12800	ACS800-17-1810-3	4xR8i
U_N = 500 V (Range 380-500 V). The power ratings are valid at nominal voltage 500 V.											
120	168	75	114	75	88	55	73	2.4	500	ACS800-17-0070-5	R6
139	234	90	132	90	114	75	73	2.8	500	ACS800-17-0100-5	R6
156	264	110	148 ¹⁾	90	125	75	73	3.4	500	ACS800-17-0120-5	R6
200	291	132	192	132	150	90	74	6	1300	ACS800-17-0170-5	R7i
245	356	160	235 ²⁾	160	183	110	74	8	1300	ACS800-17-0210-5	R7i
302	438	200	289 ³⁾	200	226	132	75	8	3160	ACS800-17-0260-5	R8i
365	530	250	350 ⁴⁾	250	273	160	75	10	3160	ACS800-17-0320-5	R8i
455	660	315	437	315	340	200	75	12	3160	ACS800-17-0400-5	R8i
525	762	355	504	355	393	250	75	14	3160	ACS800-17-0460-5	R8i
595	863	400	571	400	445	315	75	16	3160	ACS800-17-0510-5	R8i
670	972	500	643	450	501	315	75	19	3160	ACS800-17-0580-5	R8i
892	1294	630	856	630	667	450	77	24	6400	ACS800-17-0780-5	2xR8i
1005	1458	710	965	630	752	500	77	28	6400	ACS800-17-0870-5	2xR8i
1313	1906	900	1261	900	982	710	77	36	6400	ACS800-17-1140-5	2xR8i
1528	2217	1120	1467	1120	1143	800	78	41	10240	ACS800-17-1330-5	3xR8i
1884	2734	1400	1809	1300	1409	1000	78	52	10240	ACS800-17-1640-5	3xR8i
2486	3608	1800	2387	1700	1860	1300	79	68	12800	ACS800-17-2160-5	4xR8i

- ¹⁾ 156 A is allowed at 460 V.
- ²⁾ 240 A is allowed at 460 V.
- ³⁾ 302 A is allowed at 460 V.
- ⁴⁾ 361 A is allowed at 460 V.



Ratings and dimensions

ACS800-17



ACS800 - 17 - XXXX - 7 + XXXX

Nominal ratings		No-overload use	Light-overload use		Heavy-duty use		Noise level	Heat dissipation	Air flow	Type code	Frame size
$I_{cont,max}$ A	I_{max} A	$P_{cont,max}$ kW	I_N A	P_N kW	I_{hd} A	P_{hd} kW	dBA	kW	m ³ /h		
$U_N = 690$ V (Range 525-690 V). The power ratings are valid at nominal voltage 690 V.											
57 ¹⁾	86	55	54	45	43	37	73	1.8	500	ACS800-17-0060-7	R6
79	120	75	75	55	60	55	73	2.4	500	ACS800-17-0070-7	R6
93 ²⁾	142	90	88	75	71	55	73	2.8	500	ACS800-17-0100-7	R6
132	192	110	127	110	99	90	74	7	1300	ACS800-17-0160-7	R7i
150	218	132	144	132	112	90	74	8	1300	ACS800-17-0200-7	R7i
201	301	200	193	160	150	132	75	11	3160	ACS800-17-0260-7	R8i
279	417	250	268	250	209	200	75	12	3160	ACS800-17-0320-7	R8i
335	502	315	322	250	251	200	75	16	3160	ACS800-17-0400-7	R8i
382	571	355	367	355	286	270	75	17	3160	ACS800-17-0440-7	R8i
447	668	450	429	400	334	315	75	18	3160	ACS800-17-0540-7	R8i
659	985	630	632	630	493	450	77	33	6400	ACS800-17-0790-7	2xR8i
729	1091	710	700	710	545	500	77	32	6400	ACS800-17-0870-7	2xR8i
876	1310	900	840	800	655	630	77	36	6400	ACS800-17-1050-7	2xR8i
1112	1663	1120	1067	1120	831	800	78	48	10240	ACS800-17-1330-7	3xR8i
1256	1879	1250	1206	1200	940	900	78	51	10240	ACS800-17-1510-7	3xR8i
1657	2480	1700	1591	1600	1240	1200	79	67	12800	ACS800-17-1980-7	4xR8i
2321	3472	2300	2228	2300	1736	1600	79	94	17920	ACS800-17-2780-7	5xR8i
2460	3680	2500	2362	2400	1840	1800	79	99	19200	ACS800-17-2940-7	6xR8i

Enclosure

Degree of Protection:

IP21 (Standard)
IP22, IP42, IP54, IP54R (Optional)

Paint color:

Light beige RAL 7035 semi-gloss

Frame size	Width mm	Height IP21/22/42 mm	Height IP54 mm	Depth ^{E)} mm	Depth top exit ^{E)} mm	Weight kg
R6	430	2130	2315	646	646	250
R7i	630 ^{A)}	2130	2315	646	646	400
R8i	1230 ^{B)}	2130	2315	646	646	950
2xR8i	2430 ^{C)}	2130	2315	646	776 ^{F)}	2000
3xR8i	3230	2130	2315	646	776 ^{F)}	3060
4xR8i	3830 ^{D)}	2130	2315	646	776 ^{F)}	3600
5xR8i	5130 ^{D)}	2130	2315	646	776 ^{F)}	4780
6xR8i	5330 ^{D)}	2130	2315	646	776 ^{F)}	4930

Note:

¹⁾ 62 A is allowed at 575 V.

²⁾ 99 A is allowed at 575 V.

^{A)} 930 mm if equipped with 1st environment (C2) or with du/dt filter in marine version.

^{B)} 1530 mm if equipped with 1st environment filter and common motor terminal.

^{C)} 2730 mm if equipped with 1st environment filter (only types 0640-3/0770-3/0780-5/0870-5).

^{D)} Add 300 mm if top entry.

^{E)} The depth without the handle.

^{F)} The depth is 646 mm if common motor terminal is used.

Nominal Ratings:

$I_{cont,max}$: rated current available continuously without overloadability at 40°C.

I_{max} : maximum output current. Available for 10 s at start, otherwise as long as allowed by drive temperature.

Note: max. motor shaft power is 150% P_{hd} .

Typical Ratings:

No-overload use

$P_{cont,max}$: typical motor power in no-overload use.

Light-overload use

I_N : continuous current allowing 110% I_N for 1 min / 5 min at 40°C.

P_N : typical motor power in light-overload use.

Heavy-duty use

I_{hd} : continuous current allowing 150% I_{hd} for 1 min / 5 min at 40°C.

P_{hd} : typical motor power in heavy-duty use.

The current ratings are the same regardless of the supply voltage within one voltage range.

The ratings apply at 40°C ambient temperature. At higher temperatures (up to 50°C) the derating is 1% / 1°C.

For sine filter selections and ratings, contact ABB.

Cabinet-built low harmonic drives

ACS800-37, up to 2800 kW



Easy low harmonic solution

ABB's low harmonic drives offer an easy low harmonic solution incorporated in the drive. The solution to overcome harmonic issues simply comes with the drive without the need for additional filtering equipment or complicated multi-pulse transformer arrangements.

Meets the strictest standards

The ACS800-37 is a low harmonic drive in the cabinet-built power range. It is equipped with an inbuilt active supply unit and low harmonic line filter. The result is exceptionally low harmonic content in the network, with a total current distortion of less than 5.0%. That exceeds, for example, the requirements set by standard IEEE519 even in the weakest network. The ACS800-37 provides you with a simple, compact solution to meet stringent power quality standards.

Beats external solutions

When compared to multi-pulse transformer solutions, the ACS800-37 does not require a dedicated transformer and thus is simpler in terms of cabling arrangements and requires less floor space. Harmonic performance is better than with 12- and 18-pulse solutions, handling online imbalance or other shortcomings in the supply network. Passive or active external filtering devices are avoided with the ACS800-37, making the solution compact and simple. Another advantage of the ACS800-37 is that it always operates with power factor 1.

Extensive range of features

In line with other ACS800 cabinet-built drives, the ACS800-37 offers a wide variety of standardized configurations to adapt to different application requirements. It has an extensive range of inbuilt features and accessories. The smart module concept enables easy maintenance and redundancy in the high power range.

Main standard features

- Compact design
- IP21 protection degree

- Active supply unit
- Inbuilt low harmonic filter
- EMC filter for 2nd environment, unrestricted distribution according to EN 61800-3 (option in frame size R6) (category C3)
- Main switch with aR fuses (in frame sizes R6-R8i)
- Line contactor (in frame sizes R6-R8i)
- Removable air circuit breaker (in frame sizes nxR8i)
- du/dt filters (standard in frame sizes nxR8i)
- Common mode filters for motor protection (in frame sizes R7i-nxR8i)
- Coated boards
- Extensive, programmable I/O
- Long lifetime cooling fan and capacitors
- Inputs galvanically isolated
- I/O and fieldbus extension slots inside
- Alphanumeric multilingual control panel with a start-up assistant feature

Accessories for ACS800-37

- Analogue and digital I/O extension modules
- ATEX approved motor protection
- Braking chopper and resistor
- Cabinet heater
- Customer terminal block
- du/dt filters (in frame sizes R6-R8i)
- Earth fault monitoring for unearthed network
- EMC filter for 1st environment, restricted distribution according to EN 61800-3 (category C2)
- Fieldbus modules
- IP22, IP42, IP54 or IP54R protection degrees
- Emergency stop, category 0 or 1
- Marine construction
- Output for motor fan
- Pulse encoder interface module
- Prevention of unexpected start up of motor
- Top entry and exit of cables
- 1 or 2 thermistor relays
- 3.5 or 8 Pt100 relays

Plus tailor made accessories through ABB's application engineering.



Ratings and dimensions

ACS800-37

ACS800 - 37 - XXXX - 3 + XXXX
5

Nominal ratings		No-overload use	Light-overload use		Heavy-duty use		Noise level	Heat dissipation	Air flow	Type code	Frame size
$I_{cont,max}$ A	I_{max} A	$P_{cont,max}$ kW	I_N A	P_N kW	I_{hd} A	P_{hd} kW	dBA	kW	m ³ /h		
$U_N = 400$ V (Range 380-415 V). The power ratings are valid at nominal voltage 400 V.											
120	168	55	114	55	88	45	73	1.8	500	ACS800-37-0060-3	R6
150	234	75	142	75	117	55	73	2.4	500	ACS800-37-0070-3	R6
165	264	90	157	75	132	75	73	2.8	500	ACS800-37-0100-3	R6
202	293	110	194	90	151	75	74	6	1300	ACS800-37-0140-3	R7i
250	363	132	240	132	187	90	74	7	1300	ACS800-37-0170-3	R7i
292	400	160	280	160	218	110	75	7	3160	ACS800-37-0210-3	R8i
370	506	200	355	200	277	132	75	9	3160	ACS800-37-0260-3	R8i
469	642	250	450	250	351	200	75	11	3160	ACS800-37-0320-3	R8i
565	773	315	542	315	423	250	75	14	3160	ACS800-37-0390-3	R8i
730	1000	400	701	355	546	250	75	20	3160	ACS800-37-0510-3	R8i
919	1258	500	882	500	688	355	77	22	6400	ACS800-37-0640-3	2xR8i
1111	1521	630	1067	630	831	450	77	28	6400	ACS800-37-0770-3	2xR8i
1379	1888	800	1324	710	1031	560	77	36	6400	ACS800-37-0960-3	2xR8i
1535	2102	900	1474	800	1149	630	78	39	10240	ACS800-37-1070-3	3xR8i
2056	2814	1200	1973	1100	1538	800	78	54	10240	ACS800-37-1430-3	3xR8i
2610	3573	1600	2506	1400	1953	1100	79	67	12800	ACS800-37-1810-3	4xR8i
$U_N = 500$ V (Range 380-500 V). The power ratings are valid at nominal voltage 500 V.											
120	168	75	114	75	88	55	73	2.4	500	ACS800-37-0070-5	R6
139	234	90	132	90	114	75	73	2.8	500	ACS800-37-0100-5	R6
156	264	110	148 ¹⁾	90	125	75	73	3.4	500	ACS800-37-0120-5	R6
200	291	132	192	132	150	90	74	6	1300	ACS800-37-0170-5	R7i
245	355	160	235 ²⁾	160	183	110	74	8	1300	ACS800-37-0210-5	R7i
302	438	200	289 ³⁾	200	226	132	75	8	3160	ACS800-37-0260-5	R8i
365	530	250	350 ⁴⁾	250	273	160	75	10	3160	ACS800-37-0320-5	R8i
455	660	315	437	315	340	200	75	12	3160	ACS800-37-0400-5	R8i
525	762	355	504	355	393	250	75	14	3160	ACS800-37-0460-5	R8i
595	863	400	571	400	445	315	75	16	3160	ACS800-37-0510-5	R8i
700	1016	500	672	450	524	315	75	20	3160	ACS800-37-0610-5	R8i
892	1294	630	856	630	667	450	77	24	6400	ACS800-37-0780-5	2xR8i
1005	1458	710	965	630	752	500	77	28	6400	ACS800-37-0870-5	2xR8i
1338	1941	900	1284	900	1001	710	77	38	6400	ACS800-37-1160-5	2xR8i
1528	2217	1120	1467	1120	1143	800	78	41	10240	ACS800-37-1330-5	3xR8i
2037	2956	1400	1956	1300	1524	1000	78	58	10240	ACS800-37-1820-5	3xR8i
2529	3670	1800	2428	1700	1892	1300	79	70	12800	ACS800-37-2200-5	4xR8i

- ¹⁾ 156 A is allowed at 460 V.
- ²⁾ 240 A is allowed at 460 V.
- ³⁾ 302 A is allowed at 460 V.
- ⁴⁾ 361 A is allowed at 460 V.





Ratings and dimensions

ACS800-37

ACS800 - 37 - XXXX - 7 + XXXX

Nominal ratings		No-overload use	Light-overload use		Heavy-duty use		Noise level	Heat dissipation	Air flow	Type code	Frame size
$I_{cont,max}$ A	I_{max} A	$P_{cont,max}$ kW	I_N A	P_N kW	I_{hd} A	P_{hd} kW	dBA	kW	m ³ /h		
$U_N = 690$ V (Range 525-690 V). The power ratings are valid at nominal voltage 690 V.											
57 ¹⁾	86	55	54	45	43	37	73	1.8	500	ACS800-37-0060-7	R6
79	120	75	75	55	60	55	73	2.4	500	ACS800-37-0070-7	R6
93 ²⁾	142	90	88	75	71	55	73	2.8	500	ACS800-37-0100-7	R6
139	202	132	133	110	104	90	74	7	1300	ACS800-37-0170-7	R7i
162	235	160	156	132	121	110	74	8	1300	ACS800-37-0210-7	R7i
201	301	200	193	160	150	132	75	11	3160	ACS800-37-0260-7	R8i
279	417	250	268	250	209	200	75	12	3160	ACS800-37-0320-7	R8i
335	502	315	322	250	251	200	75	16	3160	ACS800-37-0400-7	R8i
382	571	355	367	355	286	270	75	17	3160	ACS800-37-0440-7	R8i
447	668	450	429	400	334	315	75	18	3160	ACS800-37-0540-7	R8i
659	985	630	632	630	493	450	77	33	6400	ACS800-37-0790-7	2xR8i
729	1091	710	700	710	545	500	77	32	6400	ACS800-37-0870-7	2xR8i
953	1425	900	914	900	713	710	77	39	6400	ACS800-37-1160-7	2xR8i
1112	1663	1120	1067	1120	831	800	78	48	10240	ACS800-37-1330-7	3xR8i
1256	1879	1250	1206	1200	940	900	78	51	10240	ACS800-37-1510-7	3xR8i
1856	2791	1800	1791	1750	1396	1400	79	77	12800	ACS800-37-2320-7	4xR8i
2321	3472	2300	2228	2300	1736	1600	79	94	17920	ACS800-37-2780-7	5xR8i
2665	3987	2700	2559	2600	1999	2000	79	114	19200	ACS800-37-3310-7	6xR8i

Enclosure

Degree of Protection:
IP21 (Standard)
IP22, IP42, IP54, IP54R (Optional)
Paint color:
Light beige RAL 7035 semi-gloss

Frame size	Width mm	Height IP21/22/42 mm	Height IP54 mm	Depth ^{E)} mm	Depth top exit ^{E)} mm	Weight kg
R6	430	2130	2315	646	646	250
R7i	630 ^{A)}	2130	2315	646	646	400
R8i	1230 ^{B)}	2130	2315	646	646	950
2xR8i	2430 ^{C)}	2130	2315	646	776 ^{F)}	2000
3xR8i	3230	2130	2315	646	776 ^{F)}	3060
4xR8i	3830 ^{D)}	2130	2315	646	776 ^{F)}	3600
5xR8i	5130 ^{D)}	2130	2315	646	776 ^{F)}	4780
6xR8i	5330 ^{D)}	2130	2315	646	776 ^{F)}	4930

Note:
¹⁾ 62 A is allowed at 575 V.
²⁾ 99 A is allowed at 575 V.

Alternatives in reducing line harmonics

6 pulse rectifier	12 pulse rectifier	18 pulse rectifier	ACS800-37
Transformer and cabling simple	Transformer and cabling complicated	Transformer and cabling complicated	Transformer and cabling simple
Current very distorted >I _{thd} 30%	Current distorted >I _{thd} 12%	Current wave form good >I _{thd} 6%	Current wave form best I _{thd} 4%

^{A)} 930 mm if equipped with 1st environment (C2) or with du/dt filter in marine version.
^{B)} 1530 mm if equipped with 1st environment filter and common motor terminal.
^{C)} 2730 mm if equipped with 1st environment filter (only types 0640-3/0770-3/0780-5/0870-5).
^{D)} Add 300 mm if top entry.
^{E)} The depth without the handle.
^{F)} The depth is 646 mm if common motor terminal is used.

Nominal Ratings:
 $I_{cont,max}$: rated current available continuously without overloadability at 40°C.

I_{max} : maximum output current. Available for 10 s at start, otherwise as long as allowed by drive temperature.
Note: max. motor shaft power is 150% P_{hd} .

Typical Ratings:
No-overload use
 $P_{cont,max}$: typical motor power in no-overload use.

Light-overload use
 I_N : continuous current allowing 110% I_N for 1 min / 5 min at 40°C.
 P_N : typical motor power in light-overload use.

Heavy-duty use
 I_{hd} : continuous current allowing 150% I_{hd} for 1 min / 5 min at 40°C.
 P_{hd} : typical motor power in heavy-duty use.

The current ratings are the same regardless of the supply voltage within one voltage range.
The ratings apply at 40°C ambient temperature. At higher temperatures (up to 50°C) the derating is 1% / 1°C.

For sine filter selections and ratings, contact ABB.



Brake options

Brake chopper

The ACS800 series has inbuilt brake choppers for all types. Therefore, no additional space or installation time is needed. The brake chopper is part of the standard delivery for the frame sizes R2 - R3; R4 only 690 V. For the other frames a brake chopper is a selectable option.

Braking control is integrated into the ACS800 series. It controls the braking, supervises the system status and detects failures such as brake resistor and resistor cable short circuits, chopper short circuit, and calculated resistor overtemperature.

Brake resistor

The SACE/SAFUR brake resistors are separately available for all ACS800 types. Resistors other than the standard resistors may be used providing the specified resistance value is not decreased, and the heat dissipation capacity of the resistor is sufficient for the drive application.

For ACS800 units, no separate fuses in the brake circuit are required if the following conditions are met:

- The ACS800 mains cable is protected with fuses
- No mains cable/fuse overrating takes place

U_N = 230 V (Range 208-240 V)

ACS800 type	Brake chopper power	Brake resistor(s)			
	Continuous P _{brcont} [kW]	Type	R [Ohm]	E _r [kJ]	P _{rcont} [kW]
ACS800-01-0001-2	0.6	SACE08RE44	44	210	1
ACS800-01-0002-2	0.8	SACE08RE44	44	210	1
ACS800-01-0003-2	1.1	SACE08RE44	44	210	1
ACS800-01-0004-2	1.5	SACE08RE44	44	210	1
ACS800-01-0005-2	2.2	SACE15RE22	22	420	2
ACS800-01-0006-2	3	SACE15RE22	22	420	2
ACS800-01-0009-2	4	SACE15RE22	22	420	2
ACS800-01-0011-2	5.5	SACE15RE13	13	435	2
ACS800-01-0016-2	11	SAFUR90F575	8	1800	4.5
ACS800-01-0020-2	17	SAFUR90F575	8	1800	4.5
ACS800-01-0025-2	23	SAFUR80F500	6	2400	6
ACS800-01-0030-2	28	SAFUR125F500	4	3600	9
ACS800-01-0040-2	33	SAFUR125F500	4	3600	9
ACS800-01-0050-2	45	2 x SAFUR125F500	2	7200	18
ACS800-01-0060-2	56	2 x SAFUR125F500	2	7200	18
ACS800-01-0070-2	68	2 x SAFUR125F500	2	7200	18

ACS800 type	Brake chopper power				Brake resistor(s)			
	5 / 60 s P _{br5} [kW]	10 / 60 s P _{br10} [kW]	30 / 60 s P _{br30} [kW]	Continuous P _{brcont} [kW]	Type	R [Ohm]	E _r [kJ]	P _{rcont} [kW]
ACS800-02-0080-2	68	68	68	54	SAFUR 160F380	1.78	3600	9
ACS800-02-0100-2	83	83	83	54	SAFUR 160F380	1.78	3600	9
ACS800-02-0120-2	105	67	60	40	2xSAFUR200F500	1.35	10800	27
ACS800-02-0140-2	135	135	135	84	2xSAFUR160F380	0.89	7200	18
ACS800-02-0170-2	135	135	135	84	2xSAFUR160F380	0.89	7200	18
ACS800-02-0210-2	165	165	165	98	2xSAFUR160F380	0.89	7200	18
ACS800-02-0230-2	165	165	165	113	2xSAFUR160F380	0.89	7200	18
ACS800-02-0260-2	223	170	125	64	4xSAFUR160F380	0.45	14400	36
ACS800-02-0300-2	223	170	125	64	4xSAFUR160F380	0.45	14400	36

U_N = 400 V (Range 380-415 V)

ACS800 type	Brake chopper power	Brake resistor(s)			
	Continuous P _{brcont} [kW]	Type	R [Ohm]	E _r [kJ]	P _{rcont} [kW]
ACS800-01-0003-3	1.1	SACE08RE44	44	210	1
ACS800-01-0004-3	1.5	SACE08RE44	44	210	1
ACS800-01-0005-3	2.2	SACE08RE44	44	210	1
ACS800-01-0006-3	3	SACE08RE44	44	210	1
ACS800-01-0009-3	4	SACE08RE44	44	210	1
ACS800-01-0011-3	5.5	SACE15RE22	22	420	2
ACS800-01-0016-3	7.5	SACE15RE22	22	420	2
ACS800-01-0020-3	11	SACE15RE22	22	420	2
ACS800-01-0025-3	23	SACE15RE13	13	430	2
ACS800-01-0030-3	28	SACE15RE13	13	430	2
ACS800-01-0040-3	33	SAFUR90F575	8	1800	4.5
ACS800-01-0050-3	45	SAFUR90F575	8	1800	4.5
ACS800-01-0060-3	56	SAFUR90F575	8	1800	4.5
ACS800-01/07-0070-3	68	SAFUR80F500	6	2400	6
ACS800-01/07-0100-3	83	SAFUR125F500	4	3600	9
ACS800-01/07-0120-3	113	SAFUR125F500	4	3600	9

ACS800 type	Brake chopper power				Brake resistor(s)			
	5 / 60 s P _{br5} [kW]	10 / 60 s P _{br10} [kW]	30 / 60 s P _{br30} [kW]	Continuous P _{brcont} [kW]	Type	R [Ohm]	E _r [kJ]	P _{rcont} [kW]
ACS800-02/07-0140-3	135	135	100	80	SAFUR200F500	2.70	5400	13.5
ACS800-02/07-0170-3	165	150	100	80	SAFUR200F500	2.70	5400	13.5
ACS800-02/07-0210-3	165	150	100	80	SAFUR200F500	2.70	5400	13.5
ACS800-02/07-0260-3	240	240	240	173	2XSAFUR210F575	1.70	8400	21
ACS800-02/07-0320-3	300	300	300	143	2xSAFUR200F500	1.35	10800	27
ACS800-02/07-0400-3	375	375	273	130	4xSAFUR125F500	1.00	14400	36
ACS800-02/07-0440-3	473	355	237	120	4xSAFUR210F575	0.85	16800	42
ACS800-02/07-0490-3	500	355	237	120	4xSAFUR210F575	0.85	16800	42

Brake options



U_N = 500 V (Range 380-500 V)

ACS800 type	Brake chopper power	Brake resistor(s)			
	Continuous P _{brcont} [kW]	Type	R	E _r	P _{rcont}
			[Ohm]	[kJ]	[kW]
ACS800-01-0004-5	1.5	SACE08RE44	44	210	1
ACS800-01-0005-5	2.2	SACE08RE44	44	210	1
ACS800-01-0006-5	3	SACE08RE44	44	210	1
ACS800-01-0009-5	4	SACE08RE44	44	210	1
ACS800-01-0011-5	5.5	SACE08RE44	44	210	1
ACS800-01-0016-5	7.5	SACE15RE22	22	420	2
ACS800-01-0020-5	11	SACE15RE22	22	420	2
ACS800-01-0025-5	15	SACE15RE22	22	420	2
ACS800-01-0030-5	28	SACE15RE13	13	435	2
ACS800-01-0040-5	33	SACE15RE13	13	435	2
ACS800-01-0050-5	45	SAFUR90F575	8	1800	4.5
ACS800-01-0060-5	56	SAFUR90F575	8	1800	4.5
ACS800-01-0070-5	68	SAFUR90F575	8	1800	4.5
ACS800-01/07-0100-5	83	SAFUR125F500	4	3600	9
ACS800-01/07-0120-5	113	SAFUR125F500	4	3600	9
ACS800-01/07-0140-5	135	SAFUR125F500	4	3600	9

ACS800 type	Brake chopper power				Brake resistor(s)			
	5 / 60 s P _{br5} [kW]	10 / 60 s P _{br10} [kW]	30 / 60 s P _{br30} [kW]	Continuous P _{brcont} [kW]	Type	R	E _r	P _{rcont}
						[Ohm]	[kJ]	[kW]
ACS800-02/07-0170-5	165	132 ²⁾	120	80	SAFUR200F500	2.70	5400	13.5
ACS800-02/07-0210-5	198	132 ²⁾	120	80	SAFUR200F500	2.70	5400	13.5
ACS800-02/07-0260-5	198 ¹⁾	132 ²⁾	120	80	SAFUR200F500	2.70	5400	13.5
ACS800-02/07-0320-5	300	300	300	300	2xSAFUR125F500	2.00	7200	18
ACS800-02/07-0400-5	375	375	375	234	2XSAFUR210F575	1.70	8400	21
ACS800-02/07-0440-5	473	473	450	195	2xSAFUR200F500	1.35	10800	27
ACS800-02/07-0490-5	480	480	470	210	2xSAFUR200F500	1.35	10800	27
ACS800-02/07-0550-5	600	400 ⁴⁾	300	170	4xSAFUR125F500	1.00	14400	36
ACS800-02/07-0610-5	600 ³⁾	400 ⁴⁾	300	170	4xSAFUR125F500	1.00	14400	36

U_N = 690 V (Range 525-690 V)

ACS800 type	Brake chopper power	Brake resistor(s)			
	Continuous P _{brcont} [kW]	Type	R	E _r	P _{rcont}
			[Ohm]	[kJ]	[kW]
ACS800-01-0011-7	8	SACE08RE44	44	210	1
ACS800-01-0016-7	11	SACE08RE44	44	210	1
ACS800-01-0020-7	16	SACE08RE44	44	210	1
ACS800-01-0025-7	22	SACE08RE44	44	210	2
ACS800-01-0030-7	28	SACE15RE22	22	420	2
ACS800-01-0040-7	22/33 ⁸⁾	SACE15RE22	22	420	2
ACS800-01-0050-7	45	SACE15RE13	13	435	2
ACS800-01-0060-7	56	SACE15RE13	13	435	2
ACS800-01/07-0070-7	68	SAFUR90F575	8	1800	4.5
ACS800-01/07-0100-7	83	SAFUR90F575	8	1800	4.5
ACS800-01/07-0120-7	113	SAFUR80F500	6	1800	4.5

ACS800 type	Brake chopper power				Brake resistor(s)			
	5 / 60 s P _{br5} [kW]	10 / 60 s P _{br10} [kW]	30 / 60 s P _{br30} [kW]	Continuous P _{brcont} [kW]	Type	R	E _r	P _{rcont}
						[Ohm]	[kJ]	[kW]
ACS800-02/07-0140-7	125 ⁵⁾	110	90	75	SAFUR80F500	6.00	2400	6
ACS800-02/07-0170-7	125 ⁶⁾	110	90	75	SAFUR80F500	6.00	2400	6
ACS800-02/07-0210-7	125 ⁶⁾	110	90	75	SAFUR80F500	6.00	2400	6
ACS800-02/07-0260-7	135 ⁷⁾	120	100	80	SAFUR80F500	6.00	2400	6
ACS800-02/07-0320-7	300	300	300	260	SAFUR200F500	2.70	5400	13.5
ACS800-02/07-0400-7	375	375	375	375	SAFUR200F500	2.70	5400	13.5
ACS800-02/07-0440-7	430	430	430	385	SAFUR200F500	2.70	5400	13.5
ACS800-02/07-0490-7	550	400	315	225	2xSAFUR125F500	2.00	7200	18
ACS800-02/07-0550-7	550	400	315	225	2xSAFUR125F500	2.00	7200	18
ACS800-02/07-0610-7	550	400	315	225	2xSAFUR125F500	2.00	7200	18

Brake resistor	Height mm	Width mm	Depth mm	Weight kg
SACE08RE44	365	290	131	6.1
SACE15RE22	365	290	131	6.1
SACE15RE13	365	290	131	6.8
SAFUR80F500	600	300	345	14
SAFUR90F575	600	300	345	12
SAFUR180F460	1320	300	345	32
SAFUR125F500	1320	300	345	25
SAFUR200F500	1320	300	345	30
SAFUR210F575	1320	300	345	27

Additional width for ACS800-07

Resistor quantity	mm
1 x SAFUR	400
2 x SAFUR	800
4 x SAFUR	1600



SACE 15 RE 13

Maximum braking power of the ACS800 equipped with the standard chopper and the standard resistor.

P_{br5} = 5 s / 1 min.

P_{br10} = 10 s / 1 min.

P_{br30} = 30 s / 1 min.

The drive and the chopper will withstand this braking power for 5/10/30 seconds every one minute. **Note:** The braking energy transmitted to the resistor during any period shorter than 400 seconds may not exceed E_r. (E_r varies depending on the resistor).

P_{brcont} = Continuous brake chopper power. The value applies to the minimum resistance value. With a higher resistance value the P_{brcont} may increase in some ACS800-02/07 units.

R = Resistance value for the listed resistor type. **Note:** This is also the minimum allowable resistance value for the brake resistor.

E_r = Energy pulse that the resistor assembly will withstand (400 s duty cycle). This energy will heat the resistor element from 40°C to the maximum allowable temperature.

P_{rcont} = Continuous power (heat) dissipation of the resistor when placed correctly. Energy E_r dissipates in 400 seconds.

¹⁾ 240 kW possible if ambient below 33°C.

²⁾ 160 kW possible if ambient below 33°C.

³⁾ 630 kW possible if ambient below 33°C.

⁴⁾ 450 kW possible if ambient below 33°C.

⁵⁾ 135 kW possible if ambient below 33°C.

⁶⁾ 148 kW possible if ambient below 33°C.

⁷⁾ 160 kW possible if ambient below 33°C.

⁸⁾ 22 kW with standard 22 ohm resistor, 33 kW with 32-37 ohm resistor.

All brake resistors are to be installed outside the converter module.

The SACE brake resistors are inbuilt an IP21 metal housing.

The SAFUR brake resistors are inbuilt an IP00 metal frame.



Brake options

Brake chopper and resistor options for ACS800-07 in frame sizes 2xR8i and 3xR8i.

Type	Nominal ratings					Duty cycle (1 min / 5 min)		Duty cycle (10 s / 60 s)		E_r kJ	Brake chopper type	Resistor type	Additional width mm
	$P_{br,max}$ kW	R ohm	I_{max} A	I_{rms} A	$P_{cont.}$ kW	$P_{br.}$ kW	I_{rms} A	$P_{br.}$ kW	I_{rms} A				
$U_N = 400 V$													
ACS800-07-0610-3+D150	706	2x1.2	1090	298	192	606	936	706	1090	-	2xNBRA659	-	800
ACS800-07-0770-3+D150	706	2x1.2	1090	298	192	606	936	706	1090	-	2xNBRA659	-	800
ACS800-07-0870-3+D150	1058	3x1.2	1635	447	288	909	1404	1059	1635	-	3xNBRA659	-	1200
ACS800-07-1030-3+D150	1058	3x1.2	1635	447	288	909	1404	1059	1635	-	3xNBRA659	-	1200
ACS800-07-0610-3+D150+D151	706	2x1.2	1090	168	108	333	514	575	888	24000	2xNBRA659	2x(2xSAFUR180F460)	2400
ACS800-07-0770-3+D150+D151	706	2x1.2	1090	168	108	333	514	575	888	24000	2xNBRA659	2x(2xSAFUR180F460)	2400
ACS800-07-0870-3+D150+D151	1058	3x1.2	1635	252	162	500	771	862	1332	36000	3xNBRA659	3x(2xSAFUR180F460)	3600
ACS800-07-1030-3+D150+D151	1058	3x1.2	1635	252	162	500	771	862	1332	36000	3xNBRA659	3x(2xSAFUR180F460)	3600
$U_N = 500 V$													
ACS800-07-0760-5+D150	806	2x1.43	1142	272	218	634	782	806	996	-	2xNBRA659	-	800
ACS800-07-0910-5+D150	806	2x1.43	1142	272	218	634	782	806	996	-	2xNBRA659	-	800
ACS800-07-1090-5+D150	1208	3x1.43	1713	408	327	951	1173	1209	1494	-	3xNBRA659	-	1200
ACS800-07-1210-5+D150	1208	3x1.43	1713	408	327	951	1173	1209	1494	-	3xNBRA659	-	1200
ACS800-07-0760-5+D150+D151	806	2x1.35	1210	134	108	333	412	575	710	21600	2xNBRA659	2x(2xSAFUR200F500)	2400
ACS800-07-0910-5+D150+D151	806	2x1.35	1210	134	108	333	412	575	710	21600	2xNBRA659	2x(2xSAFUR200F500)	2400
ACS800-07-1090-5+D150+D151	1208	3x1.35	1815	201	162	500	618	862	1065	32400	3xNBRA659	3x(2xSAFUR200F500)	3600
ACS800-07-1210-5+D150+D151	1208	3x1.35	1815	201	162	500	618	862	1065	32400	3xNBRA659	3x(2xSAFUR200F500)	3600
$U_N = 690 V$													
ACS800-07-0750-7+D150	807	2x2.72	828	214	238	596	534	808	722	-	2xNBRA669	-	800
ACS800-07-0870-7+D150	807	2x2.72	828	214	238	596	534	808	722	-	2xNBRA669	-	800
ACS800-07-1060-7+D150	1211	3x2.72	1242	321	357	894	801	1212	1083	-	3xNBRA669	-	1200
ACS800-07-1160-7+D150	1211	3x2.72	1242	321	357	894	801	1212	1083	-	3xNBRA669	-	1200
ACS800-07-0750-7+D150+D151	807	2x1.35	1670	194	108	333	298	575	514	21600	2xNBRA669	2x(2xSAFUR200F500)	2400
ACS800-07-0870-7+D150+D151	807	2x1.35	1670	194	108	333	298	575	514	21600	2xNBRA669	2x(2xSAFUR200F500)	2400
ACS800-07-1060-7+D150+D151	1211	3x1.35	2505	291	162	500	447	862	771	32400	3xNBRA669	3x(2xSAFUR200F500)	3600
ACS800-07-1160-7+D150+D151	1211	3x1.35	2505	291	162	500	447	862	771	32400	3xNBRA669	3x(2xSAFUR200F500)	3600

Brake chopper and resistor options for ACS800-37 in frame sizes R6-2xR8i.

Type	Nominal ratings					Duty cycle (1 min / 5 min)		Duty cycle (10 s / 60 s)		E_r kJ	Brake chopper type	Resistor type	Additional width mm
	$P_{br,max}$ kW	R ohm	I_{max} A	I_{rms} A	$P_{cont.}$ kW	$P_{br.}$ kW	I_{rms} A	$P_{br.}$ kW	I_{rms} A				
$U_N = 400 V$													
ACS800-37-0060...0170-3+D150	230	1.7	384	109	70	230	355	230	355	-	NBRA658	-	400
ACS800-37-0210...0510-3+D150	353	1.2	545	149	96	303	468	353	545	-	NBRA659	-	400
ACS800-37-0640...0770-3+D150	706	2x1.2	1090	298	192	606	936	706	1090	-	2 x NBRA659	-	800
ACS800-37-0960-3+D150	1058	3x1.2	1635	447	288	909	1404	1059	1635	-	3 x NBRA659	-	1200
ACS800-37-0060...0170-3+D150+D151	230	1.7	384	65	42	130	200	224	346	8400	NBRA658	2 x SAFUR210F575	1200
ACS800-37-0210...0510-3+D150+D151	353	1.2	545	84	54	287	444	287	444	12000	NBRA659	2 x SAFUR180F460	1200
ACS800-37-0640...0770-3+D150+D151	706	2x1.2	1090	168	108	333	514	575	888	24000	2 x NBRA659	2 x (2 x SAFUR180F460)	2400
ACS800-37-0960-3+D150+D151	1058	3x1.2	1635	252	162	500	771	862	1332	36000	3 x NBRA659	3 x (2 x SAFUR180F460)	3600
$U_N = 500 V$													
ACS800-37-0070...0210-5+D150	268	2.15	380	101	81	268	331	268	331	-	NBRA658	-	400
ACS800-37-0260...0610-5+D150	403	1.43	571	136	109	317	391	403	498	-	NBRA659	-	400
ACS800-37-0780...0870-5+D150	806	2x1.43	1142	272	218	634	782	806	996	-	2 x NBRA659	-	800
ACS800-37-1160-5+D150	1208	3x1.43	1713	408	327	951	1173	1209	1494	-	3 x NBRA659	-	1200
ACS800-37-0070...0210-5+D150+D151	268	2	408	45	36	111	137	192	237	7200	NBRA658	2 x SAFUR125F500	1200
ACS800-37-0260...0610-5+D150+D151	403	1.35	605	67	54	167	206	287	355	10800	NBRA659	2 x SAFUR200F500	1200
ACS800-37-0780...0870-5+D150+D151	806	2x1.35	1210	134	108	333	412	575	710	21600	2 x NBRA659	2 x (2 x SAFUR200F500)	2400
ACS800-37-1160+D150+D151	1208	3x1.35	1815	201	162	500	618	862	1065	32400	3 x NBRA659	3 x (2 x SAFUR200F500)	3600
$U_N = 690 V$													
ACS800-37-0170...0540-7+D150	404	2.72	414	107	119	298	267	404	361	-	NBRA669	-	400
ACS800-37-0790...0870-7+D150	807	2x2.72	828	214	238	596	534	808	722	-	2 x NBRA669	-	800
ACS800-37-1160-7+D150	1211	3x2.72	1242	321	357	894	801	1212	1083	-	3 x NBRA669	-	1200
ACS800-37-0170...0540-7+D150	404	1.35	835	97	54	167	149	287	257	10800	NBRA669	2 x SAFUR200F500	1200
ACS800-37-0790...0870-7+D150	807	2x1.35	1670	194	108	333	298	575	514	21600	2 x NBRA669	2 x (2 x SAFUR200F500)	2400
ACS800-37-1160-7+D150	1211	3x1.35	2505	291	162	500	447	862	771	32400	3 x NBRA669	3 x (2 x SAFUR200F500)	3600

Brake choppers and resistors for larger types are available as customised option. The drive may limit the available braking power.

$P_{br,max}$ = Maximum short time braking power.
R = Recommended braking resistor resistance.
Also nominal resistance of corresponding SAFUR resistor.
 I_{max} = Maximum peak current during braking.
Current is achieved with recommended resistor resistance.

$P_{cont.}$ = Maximum continuous braking power.
 E_r = SAFUR resistor nominal braking capacity without forced cooling.
 $P_{br.}$ = Braking power during corresponding cycle load:
1 min / 5 min = 1 minute braking with power $P_{br.}$ and 4 minutes unload.
10 s / 60 s = 10 second braking with power $P_{br.}$ and 50 seconds unload.
 I_{rms} = Corresponding rms current per chopper during load cycle.



EMC filters

1st environment vs 2nd environment

1st environment

“1st environment includes domestic premises. It also includes establishments directly connected without intermediate transformer to a low-voltage power supply network which supplies buildings used for domestic purposes.”

2nd environment

“2nd environment includes all establishments other than those directly connected to a low voltage power supply network which supplies buildings used for domestic purposes.”

EMC - Electromagnetic Compatibility and ACS800

The electrical/electronic equipment must be able to operate without problems within an electromagnetic environment. This is called immunity. The ACS800 is designed to have adequate immunity against

interference from other equipment. Likewise, the equipment must not disturb or interfere with any other product or system within its locality. This is called emission. Each ACS800 model can be equipped with an inbuilt filter to reduce high frequency emission.

All declarations concerning CE marking can be found on the www.abb.com/motors&drives website.

EMC standards

The EMC product standard [EN 61800-3 (1996) + Amendment A11 (2000)] covers the requirements stated for drives within the EU. The new revision of EN 61800-3 (2004) product standard can be applied from now on, but latest from 1 October 2007. In some cases other standards may be applicable. The emission limits are comparable according to the following table, EMC standards.

Selecting an EMC filter

The following table gives the correct filter selection.

EMC standards

EN 61800-3/A11 (2000), product standard	EN 61800-3 (2004), product standard	EN 55011, product family standard for industrial, scientific and medical (ISM) equipment	EN 61000-6-4, generic emission standard for industrial environments	EN 61000-6-3, generic emission standard for residential, commercial and light-industrial environment
1 st environment, unrestricted distribution	Category C1	Group 1	Not applicable	Applicable
1 st environment, restricted distribution	Category C2	Group 1	Applicable	Not applicable
2 nd environment, unrestricted distribution	Category C3	Group 2	Not applicable	Not applicable
2 nd environment, restricted distribution	Category C4	Not applicable	Not applicable	Not applicable

Type	Voltage	Frame sizes	1 st environment, restricted distribution, C2, grounded network (TN)	2 nd environment, C3, grounded network (TN)	2 nd environment, C3, floating network (IT)
ACS800-01	400-500	R2-R6	+E202	+E200	- *)
	690	R2-R6	-	+E200	- *)
ACS800-11	400-500	R5-R6	+E202	+E200	- *)
ACS800-31	400-500	R5-R6	+E202	+E200	- *)
ACS800-02	400-500	R7-R8	+E202	+E210	+E210
	690	R7-R8	-	+E210	+E210
ACS800-07	400-500	R6	+E202	+E200	- *)
		R7-R8	+E202	+E210	+E210
		nxR8i	+E202 (up to 1000A)	standard	standard
	690	R6	-	+E200	- *)
		R7-R8	-	+E210	+E210
		nxR8i	-	standard	standard
ACS800-17	400-500	R6	+E202	+E200	- *)
		R7i-nxR8i	+E202 (up to 1000 A)	standard	standard
	690	R7i-nxR8i	-	standard	standard
ACS800-37	400-500	R6	+E202	+E200	- *)
		R7i-nxR8i	+E202 (up to 1000 A)	standard	standard
	690	R7i-nxR8i	-	standard	standard

*) These drives are category C4 equipment and EMC plan for installation is required.



Sine filters

ABB sine filter solution

The ACS800 sine filter solution is an ACS800 industrial drive equipped with a sine filter. It enjoys most of the premium features of the standard ACS800 industrial drive. The LC filter suppresses the high frequency components of the output voltage.

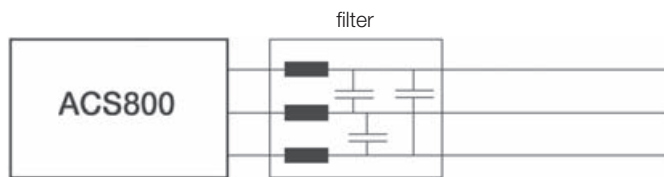

This means that the output voltage waveform is almost sinusoidal without high voltage peaks.

Filters are available in IP00 degree of protection over the whole power range. The ACS800-01 power range has also IP23 filters available. The ACS800-07 sine filter drives are complete cabinet-built units.

The ABB sine filter solution can be used in a variety of applications:

- Motor does not have adequate insulation for VSD duty
- Total motor cable length is long e.g. there are a number of parallel motors
- Step-up applications e.g. medium voltage motor needs to be driven
- Step-down applications
- There are industry specific requirements for peak voltage level and voltage rise time
- Motor noise needs to be reduced
- Maximum safety and reliability is needed in e.g. EX applications
- Submersible pumps with long motor cables e.g. in the oil industry

Main features

- Optimized LC design that takes into account switching frequency, voltage drop and filtering characteristics
- Proven technology as ABB has delivered hundreds of sine filter solutions over the last 20 years
- Cost effective solution
- Standard software has all the parameters that need to be set

Feature	Benefit	Note
Sinusoidal output voltage	No additional stress on the motor insulation: non-VSD compliant motors can be used, motor reliability and lifetime are maximized.	
	Allows the use of transformers in the drive output to match any required motor voltage.	Voltage drop at motor cable can be compensated with transformer i.e. there are no restrictions to motor cable length.
	Standard distribution transformer can be used in step-up solutions.	High starting torque is available with special transformer design.
	Less motor noise.	Usually the motor fan is the biggest noise source with sine filter solutions.
AP programming, advanced IR-compensation and flux control	The effects of load changes to motor voltage can be compensated i.e. the motor always has the optimum voltage.	Scalar control is required with sine filters.

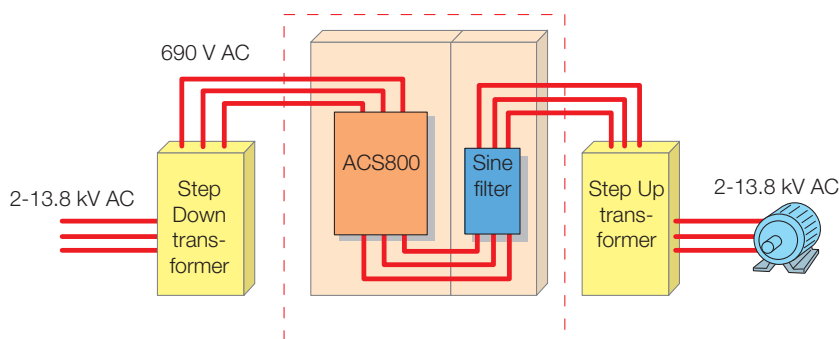



Sine filter drives

Types and ratings for ACS800-07

$I_{cont,max}$ A	$P_{cont,max}$ level kW	Noise dissipation dB	Heat size kW	Air flow height m ³ /h	Type code width	Filter depth	Total weight mm	Total mm	Total mm	Total kg
$U_N = 400\text{ V}$ (Range 380-415 V). The power ratings are valid at nominal voltage 400 V.										
206	100	79	4	1240	ACS800-07-0140-3	NSIN 0315-6	2130	1230	646	650
248	120	79	5	1240	ACS800-07-0170-3	NSIN 0315-6	2130	1230	646	650
266	130	79	6	1240	ACS800-07-0210-3	NSIN 0315-6	2130	1230	646	650
445	215	80	9	1920	ACS800-07-0260-3	NSIN 0485-6	2130	1230	646	800
521	250	80	10	3220	ACS800-07-0320-3	NSIN 0900-6	2130	1830	646	1200
602	295	80	11	3220	ACS800-07-0400-3	NSIN 0900-6	2130	1830	646	1200
693	340	80	12	3220	ACS800-07-0440-3	NSIN 0900-6	2130	1830	646	1200
720	350	80	13	3220	ACS800-07-0490-3	NSIN 0900-6	2130	1830	646	1200
879	430	81	17	5120	ACS800-07-0610-3	NSIN 1380-6	2130	2330	646	1700
1111	555	81	23	5840	ACS800-07-0770-3	NSIN 1380-6	2130	2630	646	2000
1255	630	81	25	5840	ACS800-07-0870-3	NSIN 1380-6	2130	2630	646	2000
1452	725	82	31	7840	ACS800-07-1030-3	2xNSIN 0900-6	2130	3830	646	2600
1770	885	82	36	9040	ACS800-07-1230-3	2xNSIN 1380-6	2130	4030	646	2600
2156	1080	82	46	9760	ACS800-07-1540-3	2xNSIN 1380-6	2130	4230	646	3100
2663	1330	83	56	12960	ACS800-07-1850-3	3xNSIN 1380-6	2130	5630	646	4200
$U_N = 500\text{ V}$ (Range 380-500 V). The power ratings are valid at nominal voltage 500 V.										
196	125	79	4	1240	ACS800-07-0170-5	NSIN 0315-6	2130	1230	646	650
245	150	79	5	1240	ACS800-07-0210-5	NSIN 0315-6	2130	1230	646	650
258	160	79	6	1240	ACS800-07-0260-5	NSIN 0315-6	2130	1230	646	650
440	275	80	10	1920	ACS800-07-0320-5	NSIN 0485-6	2130	1230	646	800
515	320	80	11	3220	ACS800-07-0400-5	NSIN 0900-6	2130	1830	646	1200
550	345	80	11	3220	ACS800-07-0440-5	NSIN 0900-6	2130	1830	646	1200
602	375	80	12	3220	ACS800-07-0490-5	NSIN 0900-6	2130	1830	646	1200
684	430	80	13	3220	ACS800-07-0550-5	NSIN 0900-6	2130	1830	646	1200
700	440	80	14	3220	ACS800-07-0610-5	NSIN 0900-6	2130	1830	646	1200
883	565	81	20	5120	ACS800-07-0760-5	NSIN 1380-6	2130	2330	646	1700
1050	675	81	24	5840	ACS800-07-0910-5	NSIN 1380-6	2130	2630	646	2000
1258	805	81	28	5840	ACS800-07-1090-5	NSIN 1380-6	2130	2630	646	2000
1372	880	82	33	7840	ACS800-07-1210-5	2xNSIN 0900-6	2130	3830	646	2600
1775	1135	82	41	9040	ACS800-07-1540-5	2xNSIN 1380-6	2130	4030	646	2600
2037	1305	82	48	9760	ACS800-07-1820-5	2xNSIN 1380-6	2130	4230	646	3100
2670	1710	83	63	12960	ACS800-07-2310-5	3xNSIN 1380-6	2130	5630	646	4200
$U_N = 690\text{ V}$ (Range 525-690 V). The power ratings are valid at nominal voltage 690 V.										
130	115	78	4	1240	ACS800-07-0140-7	NSIN 0210-6	2130	1230	646	650
142	125	79	5	1240	ACS800-07-0170-7	NSIN 0210-6	2130	1230	646	650
169	150	79	6	1240	ACS800-07-0210-7	NSIN 0210-6	2130	1230	646	650
315	280	80	9	1920	ACS800-07-0320-7	NSIN 0485-6	2130	1230	646	800
336	300	80	10	1920	ACS800-07-0400-7	NSIN 0485-6	2130	1230	646	800
367	330	80	11	1920	ACS800-07-0440-7	NSIN 0485-6	2130	1230	646	800
444	395	80	12	1920	ACS800-07-0550-7	NSIN 0485-6	2130	1230	646	800
628	575	81	20	5120	ACS800-07-0750-7	NSIN 0900-6	2130	2330	646	1600
729	665	81	24	5120	ACS800-07-0870-7	NSIN 0900-6	2130	2330	646	1600
885	810	81	27	5120	ACS800-07-1060-7	NSIN 1380-6	2130	2330	646	1700
953	870	81	30	5840	ACS800-07-1160-7	NSIN 1380-6	2130	2630	646	2000
1258	1150	82	39	9040	ACS800-07-1500-7	2xNSIN 0900-6	2130	4030	646	2800
1414	1290	82	45	9040	ACS800-07-1740-7	2xNSIN 0900-6	2130	4030	646	2800
1774	1620	82	56	10240	ACS800-07-2120-7	2xNSIN 1380-6	2130	4430	646	3200
1866	1705	82	60	10960	ACS800-07-2320-7	2xNSIN 1380-6	2130	4630	646	3400
2321	2070	83	72	14160	ACS800-07-2900-7	3xNSIN 1380-6	2130	5830	646	4300
2665	2435	83	82	15360	ACS800-07-3190-7	3xNSIN 1380-6	2130	6030	646	4500
2770	2530	83	89	16080	ACS800-07-3490-7	3xNSIN 1380-6	2130	6430	646	4800

Nominal Ratings:

$I_{cont,max}$: rated current of the drive-filter combination available continuously without overload at 40 °C.

Typical Ratings:

$P_{cont,max}$: typical motor power.

Notes:

Dimensions apply to IP21 and bottom entry / exit.

ACS800-17/-37: for sine filter selections and ratings, contact ABB.



du/dt filters

du/dt filtering suppresses inverter output voltage spikes and rapid voltage changes that stress motor insulation. Additionally, du/dt filtering reduces capacitive leakage currents and high frequency emission of the motor cable as well as high frequency losses and bearing currents in the motor.

The need for du/dt filtering depends on the motor insulation. For information on the construction of

the motor insulation, consult the manufacturer. If the motor does not fulfil the following requirements, the lifetime of the motor might decrease.

Insulated N-end (non-driven end) bearings and / or common mode filters are also required for motor bearing currents with motors bigger than 100 kW. For more information please see the ACS800 hardware manuals.

Filter selection table for ACS800

Motor type	Nominal mains voltage (U_N)	Motor insulation requirement
ABB M2 and M3 motors	$U_N \leq 500 \text{ V}$	Standard insulation system.
	$500 \text{ V} < U_N \leq 600 \text{ V}$	Standard insulation system in conjunction with du/dt filtering or reinforced insulation.
	$600 \text{ V} < U_N \leq 690 \text{ V}$	Reinforced insulation system in conjunction with du/dt filtering.
ABB form-wound HXR and AM motors	$380 \text{ V} < U_N \leq 690 \text{ V}$	Standard insulation system.
ABB random-wound HXR and AM motors	$380 \text{ V} < U_N \leq 690 \text{ V}$	Check motor insulation system with the motor manufacturer. du/dt filtering with voltages over 500 V.
Non-ABB Random-wound and Form-wound	$U_N \leq 420 \text{ V}$	Insulation system must withstand $\hat{U}_{LL}=1300 \text{ V}$.
	$420 \text{ V} < U_N \leq 500 \text{ V}$	If the insulation system withstands $\hat{U}_{LL}=1600 \text{ V}$ and $\Delta t=0.2 \mu\text{s}$, du/dt filtering is not required. With du/dt filtering, the insulation system must withstand $\hat{U}_{LL}=1300 \text{ V}$.
	$500 \text{ V} < U_N \leq 600 \text{ V}$	If the insulation system withstands $\hat{U}_{LL}=1800 \text{ V}$, du/dt filtering is not required. With du/dt filtering, the insulation system must withstand $\hat{U}_{LL}=1600 \text{ V}$.
	$600 \text{ V} < U_N \leq 690 \text{ V}$	If the motor insulation system withstands $\hat{U}_{LL}=2000 \text{ V}$ and $\Delta t=0.3 \mu\text{s}$, du/dt filtering is not required. With du/dt filtering, the insulation system must withstand $\hat{U}_{LL}=1800 \text{ V}$.

Symbol	Explanation
U_N	Nominal mains voltage.
\hat{U}_{LL}	Peak line to line voltage at motor terminals.
Δt	Rise time, i.e. interval during which line to line voltage at motor terminals changes from 10% to 90% of full voltage range.

du/dt filters



External du/dt filters for ACS800-01/-02/-11/-31

Applicability

ACS800			du/dt filter type (3 filters included in kits marked *)														
			Unprotected (IP00)						Protected to IP22			Protected to IP54					
			NOCH0016-60	OCH0030-60	NOCH0070-60	*NOCH0120-60	*NOCH0260-60	FOCH0260-70	FOCH0320-50	FOCH0610-70	NOCH0016-62	NOCH0070-62	NOCH0070-62	NOCH0120-62	NOCH0016-65	NOCH0030-65	NOCH0070-65
400 V	500 V	690 V															
-0003-3 -0004-3 -0005-3 -0006-3 -0009-3 -0011-3	-0004-5 -0005-5 -0006-5 -0009-5 -0011-5 -0016-5	-0011-7	1						1				1				
-0016-3 -0020-3	-0020-5	-0016-7 -0020-7 -0025-7	1						1				1				
-11-0020-3 ¹⁾ -31-0020-3 ¹⁾ -0025-3 -0030-3 -0040-3 -0050-3	-0025-5 -0030-5 -0040-5 -0050-5 -0060-5	-0030-7 -0040-7 -0050-7 -0060-7		1						1					1		
-0060-3 -0070-3	-0070-5 -0100-5	-0070-7 -0100-7 -0120-7			1							1					1
-11-0070-3 ¹⁾ -31-0070-3 ¹⁾ -0100-3 -0120-3	-11-0100-5 ¹⁾ -31-0100-5 ¹⁾ -0120-5 -0140-5			1													
-0140-3 -0170-3 -0210-3	-0170-5 -0210-5 -0260-5	-0140-7 -0170-7 -0210-7 -0260-7					1										
-0260-3	-0320-5							1									
-0320-3 -0400-3 -0440-3 -0490-3	-0400-5 -0440-5 -0490-5 -0550-5 -0610-5	-0320-7 -0400-7 -0440-7 -0490-7 -0550-7 -0610-7							1								

Factory-installed du/dt filters are available for the ACS800-07/-17/-37. They are installed inside the drive cabinet. The filters are also separately available for other ACS800 types.

Separate filters need to be mounted separately. Unprotected IP00 filters must be placed into an enclosure of adequate degree of protection.

¹⁾ Note the exceptions in ACS800-11-0020-3, ACS800-11-0070-3 and ACS800-11-0100-5 and ACS800-31-0020-3, ACS800-31-0070-3 and ACS800-31-0100-5.

Dimensions and weights of the du/dt filters

du/dt filter	Height mm	Width mm	Depth mm	Weight kg
NOCH0016-60	195	140	115	2.4
NOCH0016-62/65	323	199	154	6
NOCH0030-60	215	165	130	4.7
NOCH0030-62/65	348	249	172	9
NOCH0070-60	261	180	150	9.5
NOCH0070-62/65	433	279	202	15.5
NOCH0120-60**	200	154	106	7
NOCH0120-62/65	765	308	256	45
NOCH0260-60**	383	185	111	12
FOCH0260-70	382	340	254	47
FOCH0320-50	662	319	293	65
FOCH0610-70	662	319	293	65

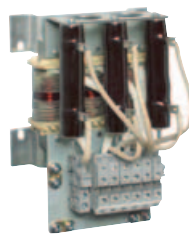

NOCH0016-60



NOCH0016-62



NOCH0016-65



FOCH0610-70

** 3 filters included, dimensions apply for one filter.



Standard user interface

Control panel

The industrial drive control panel has a multilingual alphanumeric display (4 lines x 20 characters) with plain text messages in 14 languages.

The control panel is removable and can be mounted on the drive enclosure or remotely.

```
1 L -> 1242.0 RPM 1
SPEED 1242.0 RPM
CURRENT 76.00 A
TORQUE 86.00 %
```



Start-up assistant

Easy commissioning with the start-up assistant. The start-up assistant actively guides you through the commissioning procedure step by step. It also has a unique on-line help function.

```
MOTOR SETUP 4/10
MOTOR NOM CURRENT ?
(75.5 A)
ENTER: OK RESET: BACK
```

Actual value display

The control panel can display three separate actual values simultaneously.

Examples of these are:

- Motor speed
- DC bus voltage
- Frequency
- Output voltage
- Current
- Heatsink temperature
- Torque
- Operating hours
- Power
- Kilowatt hours
- References

Fault memory

An inbuilt fault memory stores information relating to the latest 64 faults, each with a time stamp.

```
1 L -> 1242.0 RPM 1
2 LAST FAULT
OVERVOLTAGE
1121 H 1 MIN
```

Parameter copying

Parameter copy feature allows all drive parameters to be copied from one frequency converter to another to simplify commissioning.

```
1 L -> 1242.0 RPM 1
UPLOAD <=<=<
DOWNLOAD =>=>=>
CONTRAST 4
```

Centralised control

One panel can control up to 31 drives.

```
-> -> <- ->
1 21 40 100
->
111
```

Easy programming

Parameters are organised into groups for easy programming.

```
1 L -> 1242.0 RPM 1
11 REFERENCE SELECT
3 EXT REF 1 SELECT
A11
```



Standard user interface

Standard I/O

Analog and digital I/O channels are used for different functions such as control, monitoring and measurement purposes (e.g. motor temperature). In addition, optional I/O extension modules are available providing additional analog or digital I/O connections.

Standard I/O on RMIO-01 Board

- 3 analog inputs: differential, common mode voltage ± 15 V, galvanically isolated as a group.
 - One $\pm 0(2)\dots 10$ V, resolution 12 bit
 - Two $0(4)\dots 20$ mA, resolution 11 bit
- 2 analog outputs:
 - $0(4)\dots 20$ mA, resolution 10 bit
- 7 digital inputs: galvanically isolated as a group (can be split in two groups)
 - Input voltage 24 V DC
 - Filtering (HW) time 1 ms
- 3 digital (relay) outputs:
 - Changeover contact
 - 24 V DC or 115/230 V AC
 - Max. continuous current 2 A
- Reference voltage output:
 - ± 10 V $\pm 0.5\%$, max. 10 mA
- Auxiliary power supply output:
 - +24 V $\pm 10\%$, max. 250 mA

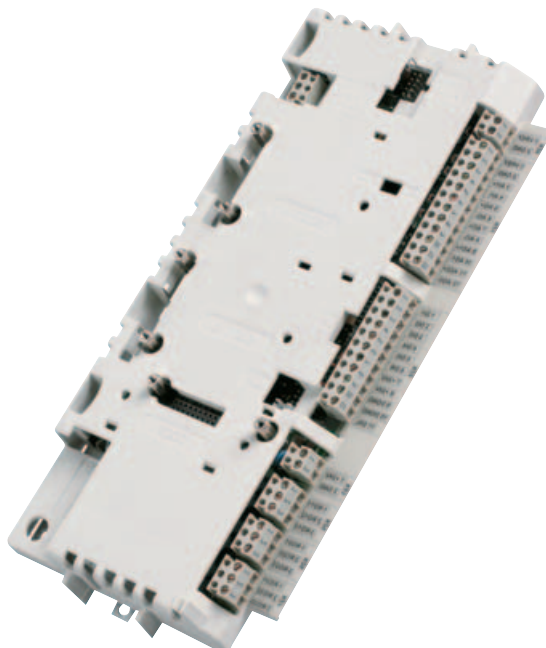

Below are the standard drive control I/O of the ABB industrial drive with Factory Macro. For other ACS800 application macros the functions may be different.

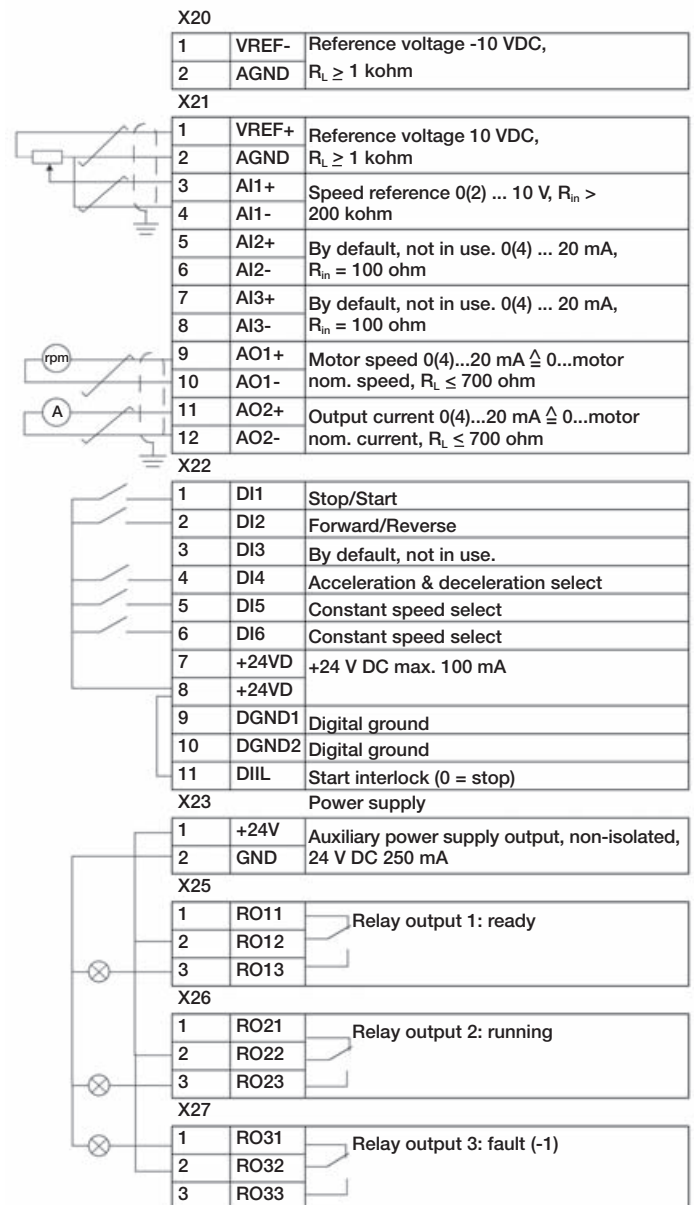



Options

Optional I/O

Standard I/O can be extended by using analog and digital extension modules or pulse encoder interface modules which are mounted in the slots on the ASC800 control board. The control board has two slots available for extension modules. More extension

modules can be added with the I/O extension adapter which has three slots. The available number and combination of I/O's depends on the control software used. The standard application software supports 2 analog and 2 digital extension modules.

Optional I/O

Analog I/O extension module RAIO-01 (+L500)

- 2 analog inputs: galvanically isolated from 24 V supply and ground
 - $\pm 0(2)\dots 10$ V, $0(4)\dots 20$ mA or $\pm 0\dots 2$ V, resolution 12 bits
- 2 analog outputs: galvanically isolated from 24 V supply and ground
 - $0(4)\dots 20$ mA, resolution 12 bit

Digital I/O extension module RDIO-01 (+L501)

- 3 digital inputs: individually galvanically isolated
 - Signal level 24 to 250 V or 115/230 V AC
- 2 relay (digital) outputs:
 - Switchover contac
 - 24 V or 115/230 V AC
 - Max. 2 A

Pulse encoder interface module RTAC-01 (+L502)

- 1 incremental encoder input:
 - Channels A, B and Z (zero pulse)
 - Signal level and power supply for the encoder is 24 or 15 V
 - Single ended or differential inputs
 - Maximum input frequency 200 kHz



I/O extension adapter AIMA-01

- Three slots for I/O extension modules
- Connection to the ACS800 control board through optic link
- Dimensions: $78 \times 325 \times 28$ mm
- Mounting: onto 35×7.5 mm DIN rail
- External power supply connection
- Supply voltage: 24 V DC $\pm 10\%$
- Current consumption: depends on connected I/O extension modules



Options

Fieldbus control

ABB industrial drives have connectivity to major automation systems. This is achieved with a dedicated gateway concept between the fieldbus systems and ABB drives.

The fieldbus gateway module can easily be mounted inside the drive. Because of the wide range of fieldbus gateways, your choice of automation system is independent of your decision to use first-class ABB AC drives.

Manufacturing flexibility

Drive control

The drive control word (16 bit) provides a wide variety of functions from start, stop and reset to ramp generator control. Typical setpoint values such as speed, torque and position can be transmitted to the drive with 15 bit accuracy.

Drive monitoring

A set of drive parameters and/or actual signals, such as torque, speed, position, current etc., can be selected for cyclic data transfer providing fast data for operators and the manufacturing process.

Drive diagnostics

Accurate and reliable diagnostic information can be obtained via the alarm, limit and fault words, reducing the drive downtime and therefore also the downtime of the manufacturing process.

Drive parameter handling

Total integration of the drives in the production process is achieved by single parameter read/write up to complete parameter set-up or download.



Reduced installation and engineering effort

Cabling

Substituting the large amount of conventional drive control cabling with a single twisted pair reduces costs and increases system reliability.

Design

The use of fieldbus control reduces engineering time at installation due to the modular structure of the hardware and software.

Commissioning and assembly

The modular machine configuration allows pre-commissioning of single machine sections and provides easy and fast assembly of the complete installation.

Currently available gateways

Fieldbus	Protocol	Device profile	Baud rate
PROFIBUS (+K454)	DP, DPV1	PROFIdrive ABB Drives*)	9.6 kbit/s - 12 Mbit/s
DeviceNet (+K451)	-	AC/DC drive ABB Drives*)	125 kbit/s - 500 kbit/s
CANopen (+K457)	-	Drives and motion control ABB Drives*)	10 kbit/s - 1 Mbit/s
ControlNet (+K462)	-	AC/DC drive ABB Drives*)	5 Mbit/s
Modbus (+K458)	RTU	ABB Drives*)	600 bit/s - 19.2 kbit/s
Ethernet (+K466)	Ethernet IP Modbus/TCP	ABB Drives*), AC/DC drive ABB Drives*)	10 Mbit/s / 100 Mbit/s
InterBUS-S (+K453)	I/O, PCP	ABB Drives*)	500 kbit/s
LONWORKS® (+K452)	LONTALK®	Variable speed motor drive	78 kbit/s

*) Vendor specific profile



Options

Remote monitoring and diagnostics tool

Browser-based, user-friendly

The intelligent ethernet NETA-01 module gives simple access to the drive via the internet, communicating via a standard web browser. The user can set up a virtual monitoring room wherever there is a PC with an internet connection or via a simple dial-up modem connection. This enables remote monitoring, configuration, diagnostics and, when needed, control. The drive can also provide process related information, such as load level, run time, energy consumption and I/O data, the bearing temperature of the driven machine, for instance.

This opens up new possibilities for the monitoring and maintenance of unmanned applications across a range of industries, for instance water, wind power, building services and oil & gas, as well as any application where the user needs access to the drives from more than one location. It also provides an opportunity for OEMs and system integrators to support their installed base globally.

With an additional Modbus TCP/OPC server the information provided by NETA-01 can be integrated with the monitoring systems.

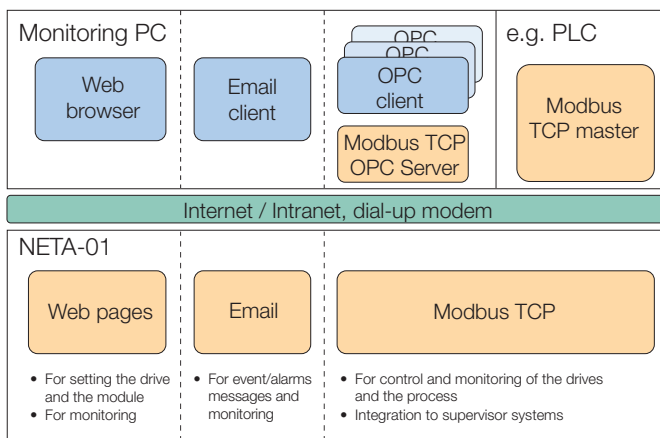

No PC needed at local end

The intelligent ethernet module has an embedded server with the necessary software for the user interface, communication and data storage. This gives ease of access, realtime information and the possibility for two-way communication with the drive, enabling immediate response and actions, saving time and money. This is possible without using a PC at the local end, as required by other remote solutions.

Powerful and versatile

Up to nine drives can be connected to the intelligent ethernet module via fiber optic links. It is available as an option for new drives, as well as an upgrade for existing systems. Access to the module is secured by user ID and passwords.

Features

- Virtual monitoring room for
- Monitoring
- Configuration of parameters
- Diagnostics
- Control, if needed
- Browser-based access via
- Intra-/extra-/internet or
- Simple dial-up modem connection
- No PC needed at the local end
- Can be used as a Modbus/TCP bridge for process control
- Supports integration with SCADA systems





Standard application software

Standard application software

Based on Direct Torque Control technology, the ACS800 offers highly advanced features as standard. The ACS800 standard application software provides solutions to virtually all AC drives applications.

Adaptive programming

In addition to parameters, industrial drives have the possibility for function block programming as standard. Adaptive programming with 15 programmable function blocks makes it possible to replace e.g. relays or even a PLC in some applications. Adaptive programming can be done either by standard control panel or DriveAP, a user-friendly PC tool.

The standard application macros

The ACS800 features inbuilt, pre-programmed application macros for configuration of such parameters as inputs, outputs and signal processing.

- FACTORY SETTINGS for basic industrial applications
- HAND/AUTO CONTROL for local and remote operation
- PID CONTROL for closed loop processes
- SEQUENTIAL CONTROL for repetitive cycles
- TORQUE CONTROL for processes where torque control is required
- USER MACRO 1 & 2 for user's own parameter settings

Software features

A complete set of standard software features offers premium functionality and flexibility.

- Accurate speed control
- Accurate torque control without speed feedback
- Adaptive programming
- Automatic reset
- Automatic start
- Constant speeds
- Controlled torque at zero speed
- DC hold
- DC magnetizing
- Diagnostics

- Flux braking
- Flux optimization
- IR compensation
- Master/follower control
- Mechanical brake control
- Motor identification
- Parameter lock
- Power loss ride-through
- Process PID control
- Programmable I/O
- Scalar control
- Speed controller tuning
- Start-up assistant
- Support for sine filter in the drive output
- Trim function
- User-selectable acceleration and deceleration ramps
- User adjustable load supervision/limitation

Pre-programmed protection functions

A wide range of features provides protection for the drive, motor and the process.

- Ambient temperature
- DC overvoltage
- DC undervoltage
- Drive temperature
- Input phase loss
- Overcurrent
- Power limits
- Short circuit

Programmable protection functions

- Adjustable power limits
- Control signal supervision
- Critical frequencies lock-out
- Current and torque limits
- Earth fault protection
- External fault
- Motor phase loss
- Motor stall protection
- Motor thermal protection
- Motor underload protection
- Panel loss

Optional application software

Control solutions for different applications



ABB provides a set of ready-made control solutions for specific industrial drive applications. Such software adds application-dedicated features and protection without an external PLC - improving productivity and reducing costs.

Main advantages of ABB's control solutions

- Application-dedicated features
- Improved production
- No external PLC
- User-friendly
- Easy to use
- Energy savings
- Smooth power loss ride-through
- Reduced costs
- Adaptive protection

Multiblock programming

The multiblock programming application has been specially designed for system integrators and local engineering because of its flexibility, easy programming, large number of I/O, master-follower link and fieldbus interfaces. Integrated into the drive control board are over 200 function blocks on 3 time levels: 20 ms, 100 ms and 500 ms. These benefits mean that it is not always necessary to have separate PLC for drive and process control.

Extended I/O

An analog and digital I/O extension is typically installed on the AIMA-01 I/O extension adapters. Three extension modules can be installed on each I/O extension adapter and an optical link connects the I/O extension adapters to the drive control board. The maximum number of I/O connections is 62.

Programming

Function blocks are easy to program using the DriveAP 2 PC tool. For example, there are PROFIBUS fieldbus blocks available to help users to understand the block program connections between the drive and Profibus master. Block program information, as well as text comments, symbolic names of block outputs and page header information is saved in the flash memory of the control board of the drive.

Pump control

Intelligent pump control software is a combination of traditional PFC which is specially designed for multi-motor pumping (or compressor, etc.) stations. While directly controlling one motor, the drive is able to start additional, direct-on-line motors whenever a higher capacity is needed.

Multipump function

Additional features such as the multipump function are designed for pumping stations that consist of multiple pumps, each controlled by a separate drive. The drives can be connected so that in the case of pump failure or maintenance action on one drive, the remaining drives continue operation - having 100% redundancy. There is an autochange function to alternate between the pumps so all pumps have an equal duty time.

Level control function

The liquid level of a container can be used as a process variable for a pumping station either filling or emptying the container when the level control function is activated. Three drives can be used in a master/follower configuration.

Flow calculation

The flow calculation contains a function that enables reasonably accurate calculation of flow without the installation of a separate flow meter.

Anti-jam function

The anti-jam function can be used for preventing solids from building up on pump impellers. The anti-jam procedure consists of a programmable sequence of forward and reverse runs of the pump, effectively shaking off any residue on the impeller.

Adaptive programming

Adaptive programming using 15 function blocks is possible with the pump control. The adaptive programming makes customizing possible without the need for a special programming tool or language.



Optional application software

Control solutions for different applications

Centrifuge control

Practical programmable sequences for conventional centrifuges. Integrated decanter control for the accurate speed difference control of two shafts, where direct communication via the fiber optic link between bowl and scroll is used.

Crane drive control

Crane drive control with optimal operational safety and performance built into the drive.

- Easy installation and start-up reduces the total project costs
- Ready to use with proven crane functionality
- Accurate and fast response increases the operational productivity
- Multiple drives can be synchronized with internal optic link, reducing the need for separate controllers. Everything needed is inbuilt
- Smooth crane operation reduces maintenance costs
- Available as single drive or multi-drive with dynamic and regenerative braking

Standard ready-to-use crane solution.

Extruder control

High starting torque, accurate speed/torque control without an encoder for demanding extruder applications. The extruder screw and other delicate mechanical parts can be protected against overload.

Master/follower control

Reliable control via the fiber optic link of several drives when they are controlled by one master. This is needed e.g. if the motor shafts are coupled together. The master/follower function enables the load to be evenly distributed between the drives.

Spinning control & traverse control

Spinning control and traverse control make a perfect pair for the precise control of spinning and traverse drives in textile machines.

System application

This application software is targeted for multi-motor machines producing or processing metal, paper, plastics, textile, rubber and cement, and for numerous other demanding applications. The basic control modes are speed control and torque control. Fast communication with the overriding controller can exchange operative data (references, command words) and support data (configuration data, diagnostics). Proprietary (DDCS, Drive bus) and generic (PROFIBUS, InterBUS-S, DeviceNet) protocols enable linking of drives to controllers, PLC and PCs.

Main features and benefits:

- Motor fan control with diagnostics
- Soft changeover between the speed and torque control modes
- Speed control gain as a function of output on low speed or as a function of motor frequency
- Thermal model for motor cable protection
- Torsional oscillation damping function to damp mechanical oscillations.

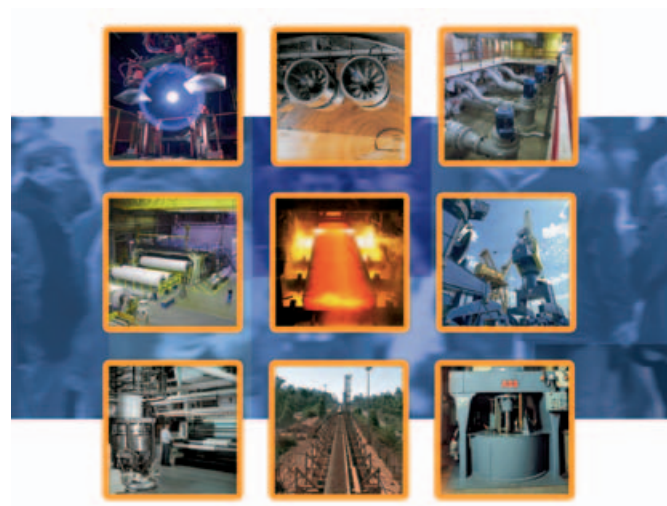



Quality dimensioning

DriveSize is a PC program for helping the user to select the optimal motor, frequency converter and transformer, especially in those cases where a straightforward selection from a catalogue is not possible. Additionally it can be used to compute currents, network harmonics and to create documents about the dimensioning based on actual load. DriveSize contains the current versions of the ABB motor and frequency converter catalogues.

The default values make DriveSize simple to use, but the user is provided with ample options for drive selection. The shortcut keys make drive selection easy while giving the optimal dimensioning result. A manual selection mode is also supported.

DriveSize is currently used by more than 1,000 engineers globally.

DriveSize is for drive system components

- 3-phase standard, customized, Ex and user defined motors
- ABB low voltage AC drives
- Transformers

DriveSize features

- Selects the optimal motor, drive unit, supply unit and transformer
- Calculates network harmonics for a single supply unit or for the whole system
- Allows importation of own motor database
- Supplies dimensioning results in graphical and numerical format
- Prints and saves the results

The DriveSize PC program can be downloaded from www.abb.com/motors&drives

- ➔ Drives
- ➔ Drive PC Tools
- ➔ DriveSize

The screenshot shows the ABB website's product page for DriveSize. The page features a navigation menu at the top with links for 'About ABB', 'Products & Services', 'Sustainability', 'News Center', 'Technology', 'Careers', and 'Investor Relations'. Below this is a secondary menu with 'ABB Product Guide', 'Systems and Industry Solutions', 'ABB Service Guide', 'Contact Directory', 'Industrial IT', and 'Supplying to ABB'. The main content area is titled 'DriveSize' and includes a description: 'DriveSize is a PC program to help select an optimal motor, frequency converter and transformer particularly in cases where a straightforward selection from a catalogue is not possible. DriveSize can also be used to compute network harmonics and to create documents about the dimensioning. It contains current versions of our motor and frequency converter catalogues.' Below the description, there is a search bar, a 'CONTACT US' section with a country selection dropdown, and a footer with links for 'Printer version', 'Email this page', and 'Bookmark this page'.



Programming tool

DriveAP is a PC software tool for creating, documenting, editing and downloading adaptive programs and multiblock programming programs. DriveAP 1.1 supports adaptive programming, whereas DriveAP 2 supports both adaptive programming and multiblock programming applications. The adaptive programming contains 15 function blocks and is available in a standard application. The multiblock programming application contains over 200 function blocks, and also includes PROFIBUS fieldbus and drive I/O blocks. DriveAP offers a clear and easy way to develop, test and document these programs with a PC.

It is a user-friendly tool for modifying function blocks and their connections. No special programming skills are required, a basic knowledge about block programming is enough. DriveAP supports IEC61131.

The adaptive programs are easy to document as hard copies or store as PC files. The multiblock programming with all related information is saved directly to the drive.

Upload or download

Both program types can be uploaded from connected drives and displayed graphically on a PC screen for service or documentation purposes, for example.

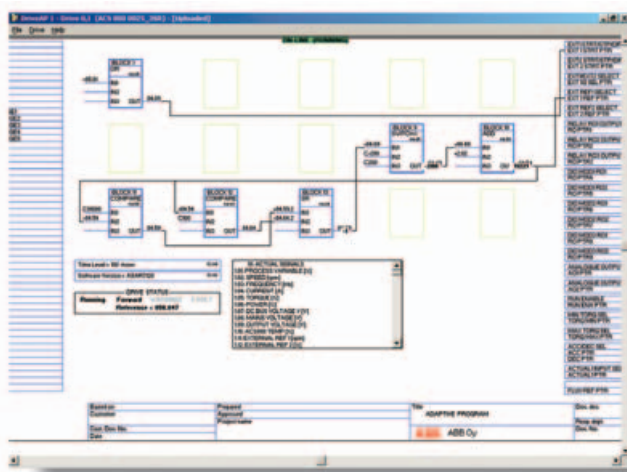

DriveAP with adaptive program of standard application.

The adaptive programs and multiblock programming programs made off-line can be downloaded to any of the connected drives that support corresponding programs.

Three operating modes

- Stand-alone mode - DriveAP is not connected to a drive. The adaptive programming and multiblock programming can be carried out in the office, for example, and later downloaded to a drive.
- Off-line mode - DriveAP is connected to a drive. The adaptive programming and multiblock programming can be carried out in batch mode.
- On-line mode - DriveAP is connected to a drive. Changes to the adaptive programs and multiblock programs are written immediately to the drive and actual values are shown on the screen in real-time.

DriveAP features

- Easy-to-use tool, no special skills required
- Create and download new programs
- Document programs
- Upload existing programs from the drive
- Operating modes
 - Stand-alone
 - Off-Line
 - On-Line

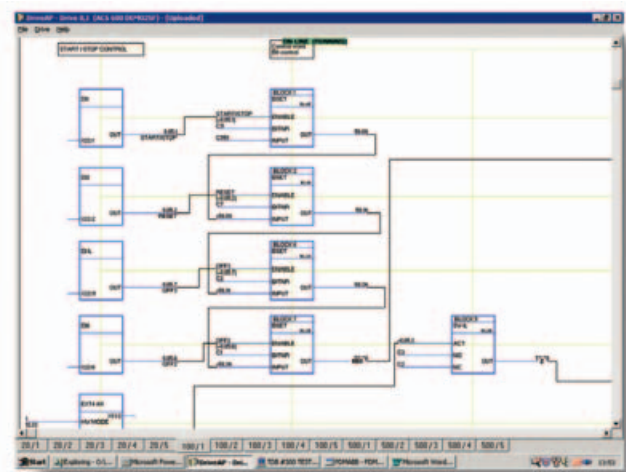

DriveAP with multiblock programming application.



DriveWindow 2

Start-up and maintenance tool

ABB's DriveWindow is an advanced, easy-to-use PC software tool for the start-up and maintenance of ABB industrial drives. Its host of features and clear, graphical presentation of the operation make it a valuable addition to your system, providing information necessary for troubleshooting, maintenance and service, as well as training.

With DriveWindow the user is able to follow the operation of several drives simultaneously by collecting the actual values from the drives onto a single screen or printout.

Additionally, the client part of DriveWindow may reside on one intranet PC, and the server on another PC closer to the drives. This enables easy plant-wide monitoring with two PCs.

High speed communication

DriveWindow uses a high-speed fibre optic cable network with DDCS communication protocol. This enables very fast communication between PC and drives. The fibre optic network is safe and highly immune to external disturbance. A fibre optic communication card inside the computer is needed.

Monitoring drives

With DriveWindow you can monitor several drives simultaneously. The history buffer makes it possible to record a large amount of data in the PC's memory. The drive's data logger can be accessed with DriveWindow and viewed in graphical form. The fault logger inside the drive automatically documents every fault, warning and event which occurs. The fault history stored in the drive can be uploaded to your computer.

Versatile back-up functions

Drive parameters can be saved to the PC with DriveWindow, and can easily be downloaded back to the drive whenever needed. The same goes for the software. DriveWindow allows the entire control board software to be saved and restored later, if needed. This makes it possible to use one control board as a spare part for many different sizes of drives.

DriveWindow 2 features

- Easy-to-use tool for commissioning and maintenance
- Several drives connected and monitored at the same time
- Monitor, edit or save signals and parameters, clear graphical presentation
- High speed communication between PC and drive
- Versatile back-up functions
- View data collected and stored in the drive
- Fault diagnostics; DriveWindow indicates the status of drives, and also reads fault history data from the drive

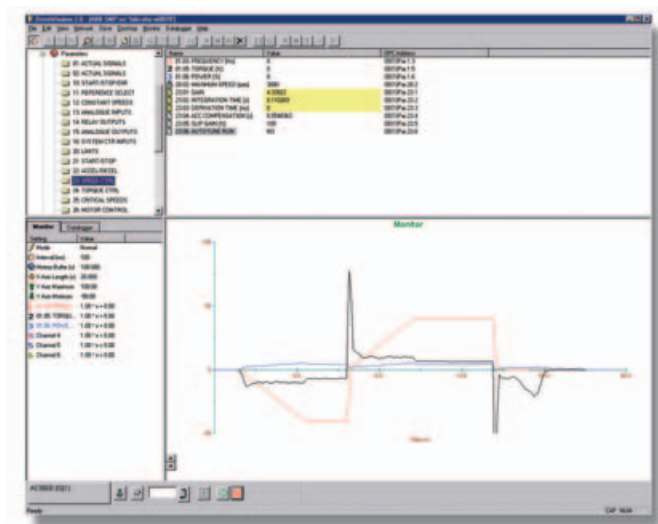



DriveWindow Light 2

Start-up and maintenance tool

DriveWindow Light 2 is an easy-to-use start-up and maintenance tool for ACS800 drives. It supports the following software: standard application, pump control, and spinning and traverse control.

DriveWindow Light uses the drive's panel connector for communication, which makes communication setup very easy.

Light software with heavy features

DriveWindow Light offers many functions in an easy-to-use package. It can be used in an offline mode, which enables parameter setting at the office even before going to the actual site. The parameter browser enables viewing, editing and saving of parameters. The parameter comparison feature makes it possible to compare parameter values between the drive and the file. With the parameter subset you can create your own parameter sets. Controlling of the drive is naturally one of the features in DriveWindow Light. With DriveWindow Light, you can monitor up to four signals simultaneously. This can be done in both graphical and numerical format. Any signal can be set to stop the monitoring from a predefined level.

Highlights

- Viewing and setting parameters in offline mode
- Editing, saving and downloading parameters
- Comparing parameters
- Graphical and numerical signal monitoring
- Drive control

DriveWindow Light requirements

- Windows 98/NT/2000/XP
- Free serial port from a PC
- Free control panel connector
- NPCU-01 PC connection unit

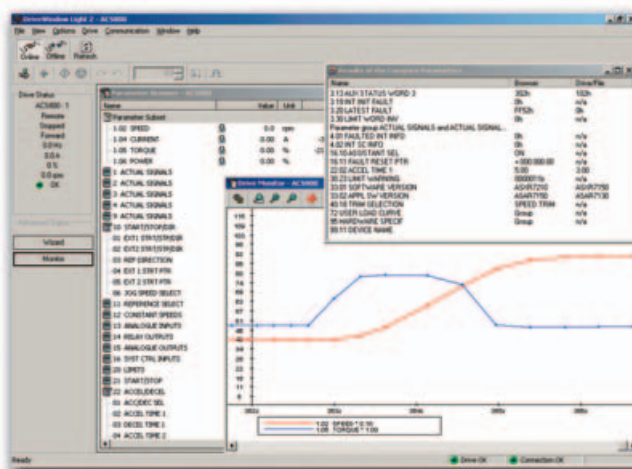



Integration tool

DriveOPC is a software package which allows OLE for Process Control (OPC) communication between Windows applications and ABB industrial drives. It allows Object Linking and Embedding (OLE) for Process Control (OPC) communication. This OPC server is an ideal tool for integrating ABB industrial drives and commercial PC software, and creating PC based control and monitoring systems.

Remote monitoring

DriveOPC enables remote connection over LAN (local area networks). The remote PC can be connected through its IP address (e.g. "164.12.43.33") or by the DNS name (e.g. "Gitas213").

OPC based software

OPC is an industry standard created in cooperation with Microsoft. It is an open architecture interface design, managed by the international OPC foundation. OPC is meant for different kinds of factory automation. DriveOPC is based on the OPC foundation data access standard 1.0A and Microsoft COM/DCOM technology. DriveOPC has full access to all drives, even when remote connection over LAN is used.

High speed communication

DriveOPC uses a high-speed fibre optic cable network with DDCS communication protocol. This makes communication between PC and drives very fast. The fibre optic network is safe and highly immune to external disturbance. A fibre optic communication card inside the computer is needed.

DriveOPC features

DriveOPC supports OPC's data access 1.0A.

Read access to:

- Drive status: local, running, direction, fault, warning, reference
- Signals and parameters
- Fault logger contents
- Event logger contents
- General drive information
- Data logger settings, status and contents

Write access to:

- Drive control: local, start, stop, forward, reverse, coast stop, reset fault, home, teach-in, contactor on/off, reference
- Parameters
- Fault logger clear
- Data logger init, start, trig, clear



Summary of features and options



Power & voltage range	Ordering	- 01	- 11	- 31	- 02	- 07	- 07	- 17	- 17	- 37	- 37
	Code					R6-R8	nxR8i	R6-R8i	nxR8i	R6-R8i	nxR8i
230 V		0.55 - 55 kW	5.5 - 45 kW	5.5 - 45 kW	45 - 200 kW	45 - 400 kW	400 - 1400 kW	45 - 400 kW	355 - 1600 kW	45 - 400 kW	355 - 1600 kW
400 V		1.1 - 110 kW	11 - 90 kW	11 - 90 kW	90 - 400 kW	90 - 400 kW	500 - 1900 kW	55 - 500 kW	450 - 1 800 kW	55 - 500 kW	450 - 1 800 kW
500 V		1.5 - 110 kW	15 - 110 kW	15 - 110 kW	110 - 500 kW	55 - 500 kW	500 - 1900 kW	55 - 500 kW	450 - 1 800 kW	55 - 500 kW	450 - 1 800 kW
690 V		5.5 - 110 kW	37 - 90 kW	37 - 90 kW	90 - 560 kW	45 - 560 kW	500 - 2800 kW	37 - 450 kW	450 - 2500 kW	37 - 450 kW	450 - 2800 kW
Mounting											
Wall mounting		●	●	●	-	-	-	-	-	-	-
Free-standing		-	-	-	●	●	●	●	●	●	●
Two mounting directions: bookshelf / flat (=sideways)		-	-	-	●	-	-	-	-	-	-
Cabling											
Bottom entry & exit		●	●	●	●	●	●	●	●	●	●
Top entry & exit	H351+ H353	-	-	-	○	□	□ 1)	□	□	□	□
Degree of protection											
IP21 (UL type 1)		●	●	●	●	●	●	●	●	●	●
IP22 (UL type 1)	B053	-	-	-	-	□	□	□	□	□	□
IP42 (UL type 1)	B054	-	-	-	-	□	□	□	□	□	□
IP54 (UL type 12)	B055	-	-	-	-	□	□	□	□	□	□
IP54R	B059	-	-	-	-	□	□	□	□	□	□
IP55 (UL type 12)	B056	□	-	-	-	-	-	-	-	-	-
DTC motor control											
DTC		●	●	●	●	●	●	●	●	●	●
Software 2)											
Start-up assistant		● 3)	● 3)	● 3)	● 3)	● 3)	● 3)	● 3)	● 3)	● 3)	● 3)
Adaptive programming		● 3)	● 3)	● 3)	● 3)	● 3)	● 3)	● 3)	● 3)	● 3)	● 3)
Optional software optimized for different applications or for enhanced programmability: for more details see section "Application software and programming"		□	□	□	□	□	□	□	□	□	□
Control panel											
Alphanumeric 4*20 character control panel		●	●	●	●	●	●	●	●	●	●
Control connections (I/O) and communications											
3 pcs analog inputs, programmable, galvanically isolated		●	●	●	●	●	●	●	●	●	●
2 pcs analog outputs, programmable		●	●	●	●	●	●	●	●	●	●
7 pcs digital inputs, programmable, galvanically isolated - can be divided into two groups		●	●	●	●	●	●	●	●	●	●
3 pcs relay outputs, programmable		●	●	●	●	●	●	●	●	●	●
Thermistor relay (1 or 2 pcs)	L505	-	-	-	○	□	□	□	□	□	□
Pt100 relays	L506	-	-	-	○ 4)	□	□	□	□	□	□
Possibility for external control voltage		●	●	●	●	●	●	●	●	●	●
Inbuilt I/O extension and speed feedback modules: for more details see section "Control connections and communications"		□	□	□	□	□	□	□	□	□	□
Inbuilt adapters for several fieldbuses: for more details see section "Control connections and communications"		□	□	□	□	□	□	□	□	□	□
EMC filters											
EMC 1 st environment (category C2)	E202	□ 5)	□	□	□ 5)	□ 5)	□ 6)	□ 5)	□ 6)	□ 5)	□ 6)
EMC 2 nd environment, earthed networks only (category C3)	E200	□	□	□	-	□ 7)	-	● 8)	●	● 8)	●
EMC 2 nd environment, earthed and unearthed networks (category C3)	E210	-	-	-	□	□ 9)	●	● 9)	●	● 9)	●



Summary of features and options

Power & voltage range	Ordering	- 01	- 11	- 31	- 02	- 07	- 07	- 17	- 17	- 37	- 37
	Code					R6-R8	nxR8i	R6-R8i	nxR8i	R6-R8i	nxR8i
230 V		0.55 - 55 kW	5.5 - 45 kW	5.5 - 45 kW	45 - 200 kW	45 - 400 kW	400 - 1400 kW	45 - 400 kW	355 - 1600 kW	45 - 400 kW	355 - 1600 kW
400 V		1.1 - 110 kW	11 - 90 kW	11 - 90 kW	90 - 400 kW	90 - 400 kW	500 - 1900 kW	55 - 500 kW	450 - 1 800 kW	55 - 500 kW	450 - 1 800 kW
500 V		1.5 - 110 kW	15 - 110 kW	15 - 110 kW	110 - 500 kW	55 - 500 kW	500 - 2800 kW	55 - 500 kW	450 - 2500 kW	55 - 500 kW	450 - 2800 kW
690 V		5.5 - 110 kW	37 - 90 kW	37 - 90 kW	90 - 560 kW	45 - 560 kW		37 - 450 kW		37 - 450 kW	450 - 2800 kW
Line filter											
AC or DC choke		●	-	-	●	●	●	-	-	-	-
LCL		-	●	●	-	-	-	●	●	●	●
Output filters											
Common mode filter	E208	-	-	-	□	□ 9)	●	□ 9)	●	□ 9)	●
du/dt filters	E205	X	X	X	X	□	●	□	●	□	●
Braking											
Brake chopper	D150	□ 10)	-	X	□	□	□	-	-	□	□
Brake resistor	D151	X	-	X	X	□ 11)	□ 11)	-	-	□ 11)	□ 11)
Regenerative braking		-	●	-	-	-	-	●	●	-	-
Rectifier bridge											
12-pulse	A004	-	-	-	-	-	□ 12)	-	-	-	-
Line side apparatus											
aR line fuses	F260	-	-	-	○	□	-	●	●	●	●
gG line fuses	F251	-	-	-	○ 13)	●	-	-	-	-	-
aR line fuses + main switch and input terminal cubicle	F253 + F260	-	-	-	-	-	□	-	-	-	-
Main switch		-	-	-	○ 13)	●	●	●	●	●	●
Line contactor + emergency stop, category 0	F250+ Q951	-	-	-	○	□	□	□	□	□	□
Line contactor + emergency stop, category 1	F250+ Q952	-	-	-	-	□	□	□	□	□	□
Line contactor without emergency stop		-	-	-	-	-	-	●	-	●	-
Air circuit breaker + emergency stop, category 0	F255+ Q951	-	-	-	-	-	□	-	□	-	□
Air circuit breaker + emergency stop, category 1	F255+ Q952	-	-	-	-	-	□	-	□	-	□
Air circuit breaker		-	-	-	-	-	-	-	●	-	●
Earthing switch	F259	-	-	-	-	-	□	-	□	-	□
Cabinet options											
Control voltage 115 VAC	G304	-	-	-	○	□	□	□	□	□	□
Control voltage 230 VAC	G320	-	-	-	○ 13)	●	●	●	●	●	●
Cabinet heater (ext. supply)	G300	-	-	-	-	□	□	□	□	□	□
Output for motor heater (ext. supply)	G313	-	-	-	-	□	□	□	□	□	□
Customized options	P902	-	-	-	-	□	□	□	□	□	□
Safety options											
Prevention of unexpected start-up	Q950	-	-	-	-	□	□	□	□	□	□
Earth fault monitoring, earthed mains		●	●	●	●	●	●	●	●	●	●
Earth fault monitoring, unearthed mains		●	●	●	●	□	□	□	□	□	□
Emergency stop (see Line side apparatus)											
Approvals											
CE		●	●	●	●	●	●	●	●	●	●
UL, cUL, CSA		● 14)	● 14)	● 14)	● 15)	□	□	□	□	□	□
GOST R		●	pending	pending	●	●	●	pending	pending	pending	pending
C-Tick		●	pending	pending	●	pending	pending	pending	pending	pending	pending
Marine design		□ 16)	-	-	-	□	□	□	□	□	□

- Standard
 - Selectable option, inbuilt
 - X Selectable option, external, no plus code
 - ACS800-02 Enclosure extension option (requires also +C111 or +C127 code)
 - Not available
- 1) IP54 or IP54R require line fuses and load switch F253 + F260.
 - 2) Software compatibility with different option modules must be checked from ACS800 software compatibility (doc no. 64638211) in ABB Library.
 - 3) Only in standard software.
 - 4) Always 3 pcs.
 - 5) Not for 690 V.
 - 6) Only 07-0610-3, 07-0760-5, 17-0640-3, 17-0770-3, 17-0780-5, 17-0870-5, 37-0640-3, 37-0770-3, 37-0780-5 and 37-0870-5.
 - 7) Available for R6 only.
 - 8) Selectable option, inbuilt in frame size R6.
 - 9) Not available for R6.
 - 10) Standard in ACS800-01 frame sizes R2 and R3 and at 690 V also in R4.
 - 11) Not available as IP54 or IP54R, or with C129 (UL approved version of the frame sizes R6 - R8 ACS800-07/ -17/ -37).
 - 12) Basic unit without line fuses and load switch can be connected to 6- or 12- pulse operation
 - 13) ACS800-02: standard in enclosure extension (C111, C127).
 - 14) UL-type 1 only.
 - 15) Option if enclosure extension is used.
 - 16) Type approval (ABS, Bureau Veritas, DNV, GL, Lloyd's and RINA) with option +C132.



Global service network

ABB provides professional spare part, maintenance and repair services using its own authorized and certified service personnel as well as the personnel of the ABB channel partners all over the world.

Note: Though all services are available globally, local services may vary.

For more information on our ACS800 services and service network, please contact your local ABB representative or visit our website: <http://www.abb.com/motors&drives>.

Productized services

ABB's drive lifecycle management model provides customers with the maximum profit for the purchased assets by maintaining high availability, eliminating unplanned repair costs and extending drive lifetime. The lifecycle management model comprises a palette of dedicated services for the entire lifecycle of ACS800 drives.

Start-up services

Using ABB's start-up services you can trust that your drives are correctly commissioned and tuned to their application. ABB global service network personnel are authorized professionals who are thoroughly trained for their job.

Service product code	Service type	Description
68281873	ACS800, (R2- R6), Distance 1*	Professional Start-up service
68281881	ACS800, (R2- R6), Distance 2*	Professional Start-up service
68281890	ACS800, (R7- R8), Distance 1*	Professional Start-up service
68281903	ACS800, (R7- R8), Distance 2*	Professional Start-up service

* Distance defined locally

Training services

ABB offers dedicated training on ACS800 drives for your service and operating personnel for acquiring the required skills to use your ABB drives correctly and safely and to run the application in the most effective way.

ACS800 single drive training courses

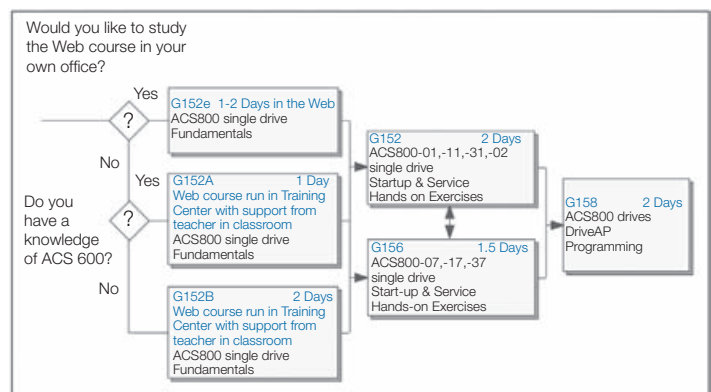

For more information on our training services, please contact your local ABB representative or visit the ABB University website: <http://www.abb.com/abbuniversity>.

Preventive maintenance

Maintenance schedules and preventive maintenance kits provide a systematic and functional means of maintaining drives. Each AC drive product serie has a unique schedule, which is based on ABB's extensive experience and know-how of manufacturing and maintaining electric drives.

Contact and web information

www.abb.com/motors&drives



ABB's worldwide presence is built on strong local companies working together with the channel partner network. By combining the experience and know-how gained in local and global markets, we ensure that our customers in all industries can gain the full benefit from our products.

For further details about all our low voltage AC drives and services please contact your nearest ABB office or ABB drives channel partner or visit the websites www.abb.com/motors&drives and www.abb.com/drivespartners.

Albania Tel: +355 4 234 368, 363 854 Fax: +355 4 363 854	Costa Rica Tel: +506 288 5484 Fax: +506 288 5482	Israel (Haifa) Tel: +972 4 850 2111 Fax: +972 4 850 2112	Norway (Oslo) Tel: +47 03500 Fax: +47 22 872 541 drives@no.abb.com	Spain (Barcelona) Tel: +34 (9)3 728 8700 Fax: +34 (9)3 728 8743
Algeria Tel: +212 2224 6168 Fax: +212 2224 6171	Croatia (Zagreb) Tel: +385 1 600 8550 Fax: +385 1 619 5111	Italy (Milan) Tel: +39 02 2414 3085 Fax: +39 02 2414 3979	Oman Tel: +968 2456 7410 Fax: +968 2456 7406	Sri Lanka (Colombo) Tel: +94 11 2399304/6 Fax: +94 11 2399303
Argentina (Valentin Alsina) Tel: +54 (0)114 229 5707 Fax: +54 (0)114 229 5593	Czech Republic (Prague) Tel: +420 234 322 327 Fax: +420 234 322 310	Ivory Coast Tel: +225 21 35 42 65 Fax: +225 21 35 04 14	Pakistan (Lahore) Tel: +92 42 6315 882-85 Fax: +92 42 6368 565	Sweden (Västerås) Tel: +46 (0)21 32 90 00 Fax: +46 (0)21 14 86 71
Australia (Victoria) Tel: +1800 222 435 Tel: +61 3 8544 0000 Fax: +61 3 8544 0004	Denmark (Skovlunde) Tel: +45 44 504 345 Fax: +45 44 504 365	Japan (Tokyo) Tel: +81(0)3 5784 6010 Fax: +81(0)3 5784 6275	Panama Tel: +507 209 5400, 2095408 Fax: +507 209 5401	Switzerland (Zürich) Tel: +41 (0)58 586 0000 Fax: +41 (0)58 586 0603
Austria (Vienna) Tel: +43 1 60109 0 Fax: +43 1 60109 8312	Dominican Republic Tel: +809 561 9010 Fax: +809 562 9011	Jordan Tel: +962 6 562 0181 Fax: +962 6 5621369	Peru (Lima) Tel: +51 1 561 0404 Fax: +51 1 561 3040	Syrian Arab Republic Tel: +9626 5620181 ext. 502 Fax: +9626 5621369
Azerbaijan Tel: +994 12 498 54 75 Fax: +994 12 493 73 56	Ecuador Tel: +593 2 2500 645 Fax: +593 2 2500 650	Kazakhstan Tel: +7 3272 583838 Fax: +7 3272 583839	The Philippines (Metro Manila) Tel: +63 2 821 7777 Fax: +63 2 823 0309, 824 4637	Taiwan (Taipei) Tel: +886 2 2577 6090 Fax: +886 2 2577 9467, 2577 9434
Bahrain Tel: +973 725 377 Fax: +973 725 332	Egypt Tel: +202 6251630 Fax: +202 6251638	Kenya (Nairobi) Tel: +254 20 828811/13 to 20 Fax: +254 20 828812/21	Poland (Lodz) Tel: +48 42 299 3000 Fax: +48 42 299 3340	Tanzania Tel: +255 51 2136750, 2136751, 2136752 Fax: +255 51 2136749
Bangladesh (Dhaka) Tel: +88 02 8856468 Fax: +88 02 8850906	Estonia (Tallinn) Tel: +372 6801 800 Fax: +372 6801 810	Kuwait Tel: +965 2428626 ext. 124 Fax: +965 2403139	Portugal (Oeiras) Tel: +351 21 425 6000 Fax: +351 21 425 6390, 425 6354	Thailand (Bangkok) Tel: +66 (0)2665 1000 Fax: +66 (0)2665 1042
Belarus (Minsk) Tel: +375 228 12 40, 228 12 42 Fax: +375 228 12 43	Ethiopia Tel: +251 1 669506, 669507 Fax: +251 1 669511	Latvia (Riga) Tel: +371 7 063 600 Fax: +371 7 063 601	Qatar Tel: +974 444 1789 Fax: +974 444 6189	Tunisia Tel: 00216 71 860 366 Fax: 00 216 71 860 255
Belgium (Zaventem) Tel: +32 2 718 6313 Fax: +32 2 718 6664	Finland (Helsinki) Tel: +358 10 22 11 Tel: +358 10 222 1999 Fax: +358 10 222 2913	Lithuania (Vilnius) Tel: +370 5 273 8300 Fax: +370 5 273 8333	Romania (Bucharest) Tel: +40 21 310 4377 Fax: +40 21 310 4383	Turkey (Istanbul) Tel: +90 216 528 2200 Fax: +90 216 365 2944
Bolivia (La Paz) Tel: +591 2 278 8181 Fax: +591 2 278 8184	France (Montluel) Tel: +33 (0)4 37 40 40 00 Fax: +33 (0)4 37 40 40 72	Luxembourg (Leudelange) Tel: +352 493 116 Fax: +352 492 859	Russia (Moscow) Tel: +7 095 960 22 00 Fax: +7 095 913 96 96/95	Uganda Tel: +256 41 348 800 Fax: +256 41 348 799
Bosnia Herzegovina (Tuzla) Tel: +387 35 246 020 Fax: +387 35 255 098	Germany (Ladenburg) Tel: +01805 222 580 Tel: +49 (0)6203 717 717 Fax: +49 (0)6203 717 600	Macedonia (Skopje) Tel: +389 2 118 010 Fax: +389 2 118 774	Saudi-Arabia (Al Khobar) Tel: +966 (0)3 882 9394, ext. 240, 254, 247 Fax: +966 (0)3 882 4603	Ukraine (Kiev) Tel: +380 44 495 22 11 Fax: +380 44 495 22 10
Brazil (Sao Paulo) Tel: 0800 014 9111 Tel: +55 11 3688 9282 Fax: +55 11 3688 9421	Greece (Athens) Tel: +30 210 289 1 651 Fax: +30 210 289 1 792	Malaysia (Kuala Lumpur) Tel: +603 5628 4888 Fax: +603 5635 8200	Senegal Tel: +221 832 1242, 832 3466 Fax: +221 832 2057, 832 1239	The United Arab Emirates (Dubai) Tel: +971 4 3147500, 3401777 Fax: +971 4 3401771, 3401539
Bulgaria (Sofia) Tel: +359 2 981 4533 Fax: +359 2 980 0846	Guatemala Tel: +502 3633814 Fax: +502 363 3624	Mauritius Tel: +230 208 7644, 211 8624 Fax: +230 211 4077	Serbia and Montenegro (Belgrade) Tel: +381 11 3094 320, 3094 300 Fax: +381 11 3094 343	United Kingdom (Manchester, Didsbury) Tel: +44 1925 741 111 Fax: +44 1925 741 693
Cameroon Tel: +237 42 23 66 Fax: +237 42 23 90	Hungary (Budapest) Tel: +36 1 443 2224 Fax: +36 1 443 2144	Mexico (Mexico City) Tel: +52 (55) 5328 1400 ext. 3008 Fax: +52 (55) 5328 7467	Singapore Tel: +65 6776 5711 Fax: +65 6778 0222	Uruguay (Montevideo) Tel: +598 2 707 7300 Tel: +598 2 707 7466
Canada (Montreal) Tel: +1 514 215 3006 Fax: +1 514 332 0609	India (Bangalore) Tel: +91 80 837 0416 Fax: +91 80 839 9173	Morocco Tel: +212 2224 6168 Fax: +212 2224 6171	Slovakia (Banska Bystrica) Tel: +421 48 410 2324 Fax: +421 48 410 2325	USA (New Berlin) Tel: +1 800 752 0696 Tel: +1 262 785 3200 Fax: +1 262 785 0397
Chile (Santiago) Tel: +56 2 471 4391 Fax: +56 2 471 4399	Indonesia (Jakarta) Tel: +62 21 590 9955 Fax: +62 21 590 0115, 590 0116	The Netherlands (Rotterdam) Tel: +31 (0)10 407 8886 Fax: +31 (0)10 407 8433	Slovenia (Ljubljana) Tel: +386 1 2445 440 Fax: +386 1 2445 490	Venezuela (Caracas) Tel: +58 212 2031949 Fax: +58 212 237 6270
China (Beijing) Tel: +86 10 5821 7788 Fax: +86 10 5821 7518, 5821 7618	Iran (Tehran) Tel: +98 21 2222 5120 Fax: +98 21 2222 5157	New Zealand (Auckland) Tel: +64 9 356 2170 Fax: +64 9 357 0019	South Africa (Johannesburg) Tel: +27 11 617 2000 Fax: +27 11 908 2061	Vietnam (Hochiminh) Tel: +84 8 8237 972 Fax: +84 8 8237 970
Colombia (Bogotá) Tel: +57 1 417 8000 Fax: +57 1 413 4086	Ireland (Dublin) Tel: +353 1 405 7300 Fax: +353 1 405 7312	Nigeria Tel: +234 1 4937 347 Fax: +234 1 4937 329	South Korea (Seoul) Tel: +82 2 528 2794 Fax: +82 2 528 2338	Zimbabwe Tel: +263 4 369 070 Fax: +263 4 369 084



ABB Oy
Drives
P. O. Box 184
FI - 00381 Helsinki
Finland
Telephone +358 10 22 11
Fax +358 10 22 22681
Internet <http://www.abb.com/motors&drives>